



# THE CHOICE OF THE PROFESSIONALS...



Introducing the complete range of L.A.D. turntables, specifically designed to add a new dimension to the World of Professional Sound.

Some of the turntables are with remote control packed with ultimate facilities. The precision engineering of the turntables designed make them an excellent choice for the use in studios, radio stations and discotheques have been built with a single-minded emphasis on Sound Quality.

The constructions of a heavy duty chassis and suspended sub chassis decouple shock waves from loudspeakers to almost negligible levels and guarantees good acoustic feedback rejection.

All the turntables have facilities for fader deck start

## SPECIFICATIONS

## MODEL GAJ942SP

- |   |   |  |
|---|---|--|
| 1 STARTING UP TIME 0 to 33 0,4sec                     | 7 SPEEDS 33and45rpmwith<br>± 8% Variation | 13 HEADSHELL Detachatte with finger lift |
| 2 STARTING TORQUE 1,5 Kg/cm                           | 8 ARM LENGTH 229mm                        | 14 DIMENSION W445 D34 H145               |
| 3 MOTOR Direct Drive Quartz/<br>Cover<br>VahaWe Motor | 9 OVERHANG 13mm                           | 15 DUST COVER Clear Acrylic              |
| 4 BRAKING SYSTEM Electronic Brake                     | 10 OFFSET ANGLE 22.5*                     | 16 WEIGHT 12Kg                           |
| 5 RUMBLE Better than 60dB                             | 11 ARM HEIGHT ADJUSTMENT<br>Up to 8mm     | 17 VOLTAGE SUPPLY 220-240<br>50-60HZ     |
| 6 WOW & FLUTTER 0,035%WTD                             | 12 STYLUS PRESSURE 0,5gm to 5gms          | 18 SPEED SELECT DISPLAY Digital LED      |



# NEW LOW COST PRECISION TURNTABLES



Design for mobile discos and clubs

## SPECIFICATIONS

## MODEL GAJ 835S MKII

- |  |  |   |
|--|--|---|
| 1 SUPPLY VOLTAGE 220-240Vdtt<br>SO-60 Hz         | 6 DRIVE Belt Driven                              | 11 HEADSHELL Detachable with<br>Finger Lift                   |
| 2 MOTOR DC Servo Coreless Motor                  | 7 REMOTE CONTROL 19'Rack<br>482.6 $\ll$ 88       | 12 CONNECTIONS FROM REM<br>2 x 1 metre long with 2 2mm socket |
| 3 STARTING TORQUE 10g/cm                         | 8 RUMBLE 55dB                                    | 13 DIMENSIONS W390xD332                                       |
| 4 STARTING UP TIME 0to33 0.3 SC                  | 9 WOW & FLUTTER 0.08% WTD                        | 14 WEIGHT 7.5Kg   |
| 5 CUEING Variable Clockwise and<br>Anticlockwise | 10 STYLUS PRESSURE<br>Adjustment range 1 to 5 gm |   |

# LAD

LONDON ACOUSTICAL  
DEVELOPMENTS LTD

## THE WORLD'S FIRST TWIN TURNTABLE WITH REMOTE CONTROL

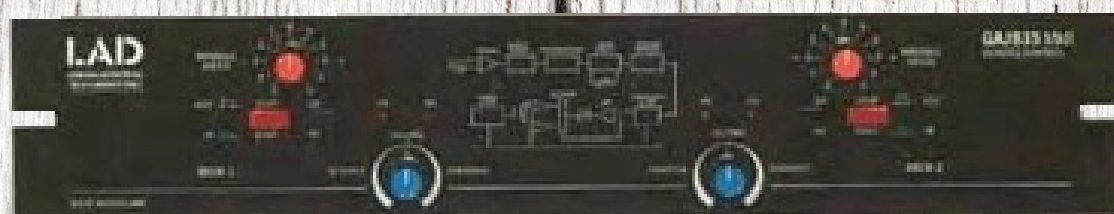

### SPECIFICATIONS

1 SUPPLY VOLTAGE 220-240Volt  
50-60 Hz

2 MOTOR K Servo Coreless Motor

3 STARTING TORQUE 1kg/cm

4 STARTING UP TIME 0to33 0,3sec

5 CUEING Variable Clockwise and  
Anticlockwise

6 DRIVE Belt Driven

7 REMOTE CONTROL 19\* Rack  
482.6x88

8 RUMBLE 55d8

9 WOW & FLUTTER 008% WTD

10 STYLUS PRESSURE  
Adjustment range 1 to5gms

11 HEADSHELL Detachable with  
Finger Lift

12 CONNECTIONS FROM DECKS 2x1  
metre long with 2 x 2mm socket

13 DIMENSIONS W760xD332

14 WEIGHT 7,5Kg

### MODEL GAJ 835MKII



# TECHNOLOGY FOR SOUND QUALITY



## SPECIFICATIONS

- 1 SUPPLY VOLTAGE 220-240 Volts 50-60 Hz
- 2 MOTOR Brushless Direct Drive DC Motor
- 3 STARTING TORQUE 800g/cm
- 4 RUMBLE Better than 60db WTD
- 5 WOW&FLUTTER 0.04%
- 6 SPEEDS 33 and 45 rpm with  $\pm 8\%$  variation
- 7 STARTING UP TIME 0 to 33 0,8sec
- 8 ARM LENGTH 229mm

## MODEL GAJ 828

- 9 ARM LENGTH ADJUSTMENT Variable from 0 to 8mm
- 10 OVERHANG 13mm
- 11 OFFSET ANGLE 22 5'
- 12 STYLUS PRESSURE 0 5g to 5gm
- 13 HEADSHEU Detachable
- 14 CONTROL PANEL Removable tan

- 15 DIMENSIONS W 410x D 320mm xH 130mm
- 16 WEIGHT 8Kg

## SPECIFICATIONS

- 1 SUPPLY VOLTAGE 220-240 Volts 50-60 Hz
- 2 MOTOR Direct Drive Quartz Brusless DC Motor
- 3 BRAKING System Electronic
- 4 RUMBLE Better than 65dB
- 5 WOW & HUTTER 0.035% WTD
- SPEEDS 33and45rpm with  $\pm 8\%$  Variation

## MODEL GAJ 828P

- 7 STARTING UP TIME 0 to 33 0,4sec
- 8 STARTING TORQUE 1,5kg/cm
- 9 ARM LENGTH 229mm
- 10 ARM LENGTH ADJUSTMENT Variable from 0 to 8mm
- 11 OVERHANG 13mm
- 12 OFFSET ANGLE 22,5"
- 13 STYLUS PRESSURE Adjustment range 0,5gm to 5gm
- 14 HEADSM&I Detachable
- 15 CONTROL PANEL Removable can be mounted on to the console
- 16 DIMENSIONS W 410 xD320mmxH 130mm
- 17 WEIGHT 8,5Kg





London Acoustical Developments Ltd

8 Hartfield Road,  
Wimbledon SW19 3TA  
England

Telephone: 01-946 6063

J25Z

Trade Price List

GAJ828 ----- £135.60

GAJ828P ----- £179.00

GAJ835 ----- £130.70

GAJ835S----- £139.00

GAJ942SP — — £193.90

JIS A-3 (297,420)

|     |                |
|-----|----------------|
| 變更者 | 變更番-記事-年月日-變更者 |
| 變更  | △×             |
| 變更  | △×             |
| 變更  | △×             |

|      |   |
|------|---|
| 寸法公差 | ± |
| ~    | ± |
| ~    | ± |

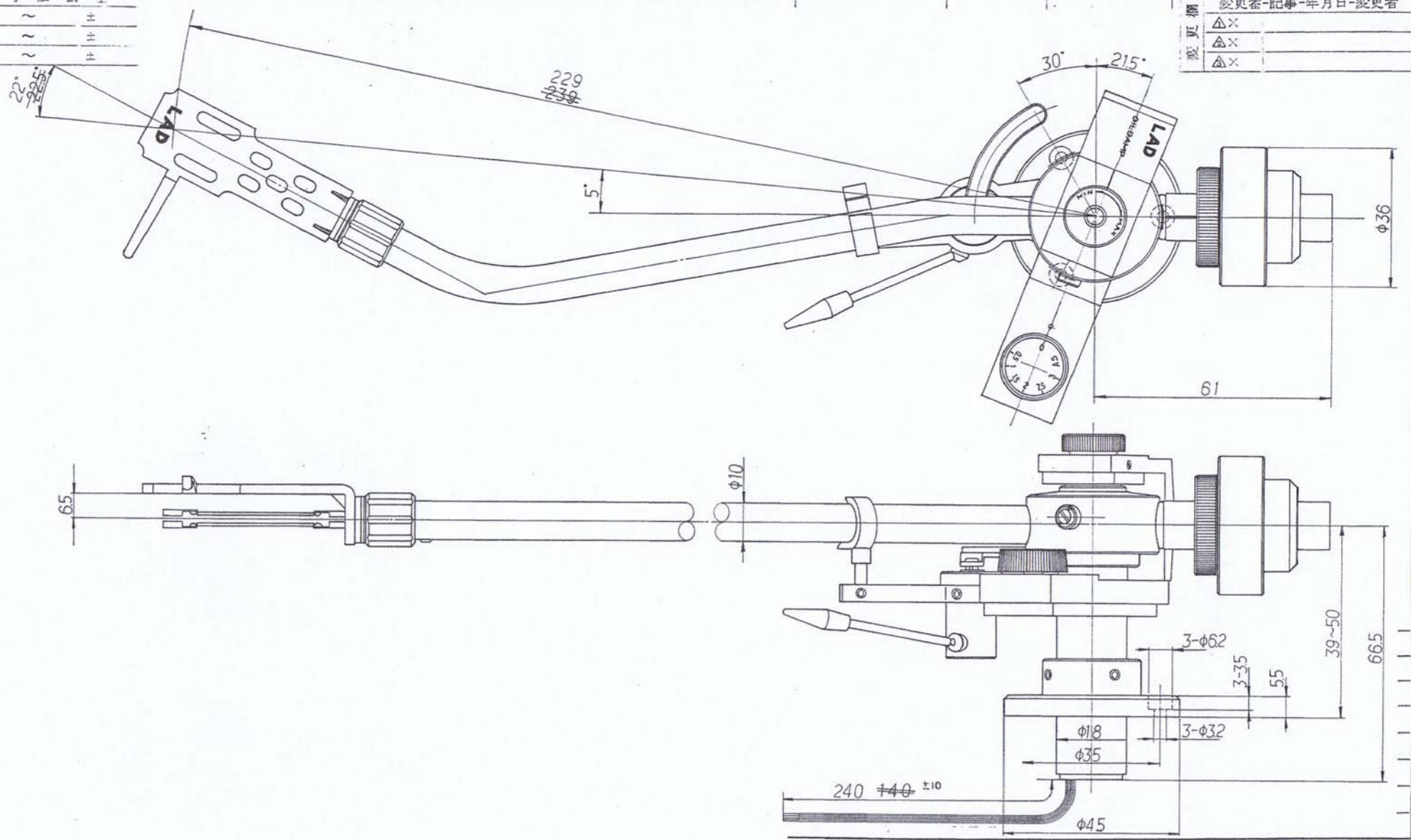

H1  
付  
本 図  
仮 図  
anew  
«OS  
試作図  
HLS®  
新配図  
交換図  
手繪完了

|    |    |      |                           |                   |    |                |
|----|----|------|---------------------------|-------------------|----|----------------|
| 個数 | 符号 | 図面番号 | 部品名                       | 材質                | 処理 | 摘要             |
|    |    |      | 品名 SA-370D MkIII TONE ARM |                   |    | 単位・mm<br>第三角図法 |
|    |    |      | 材質                        | 素材寸法              |    | %              |
|    |    |      | 処理                        | 重量                |    | g              |
|    |    |      | 設計                        | 昭和 年 月 日 照査       |    | 昭和 年 月 日 尺度    |
|    |    |      | 製図                        | 細田 昭和58年10月18日 承認 |    | 昭和 年 月 日       |
|    |    |      | 市川宝石株式会社                  | 図番                |    | 3-1939C        |

1(1.1070)3.000

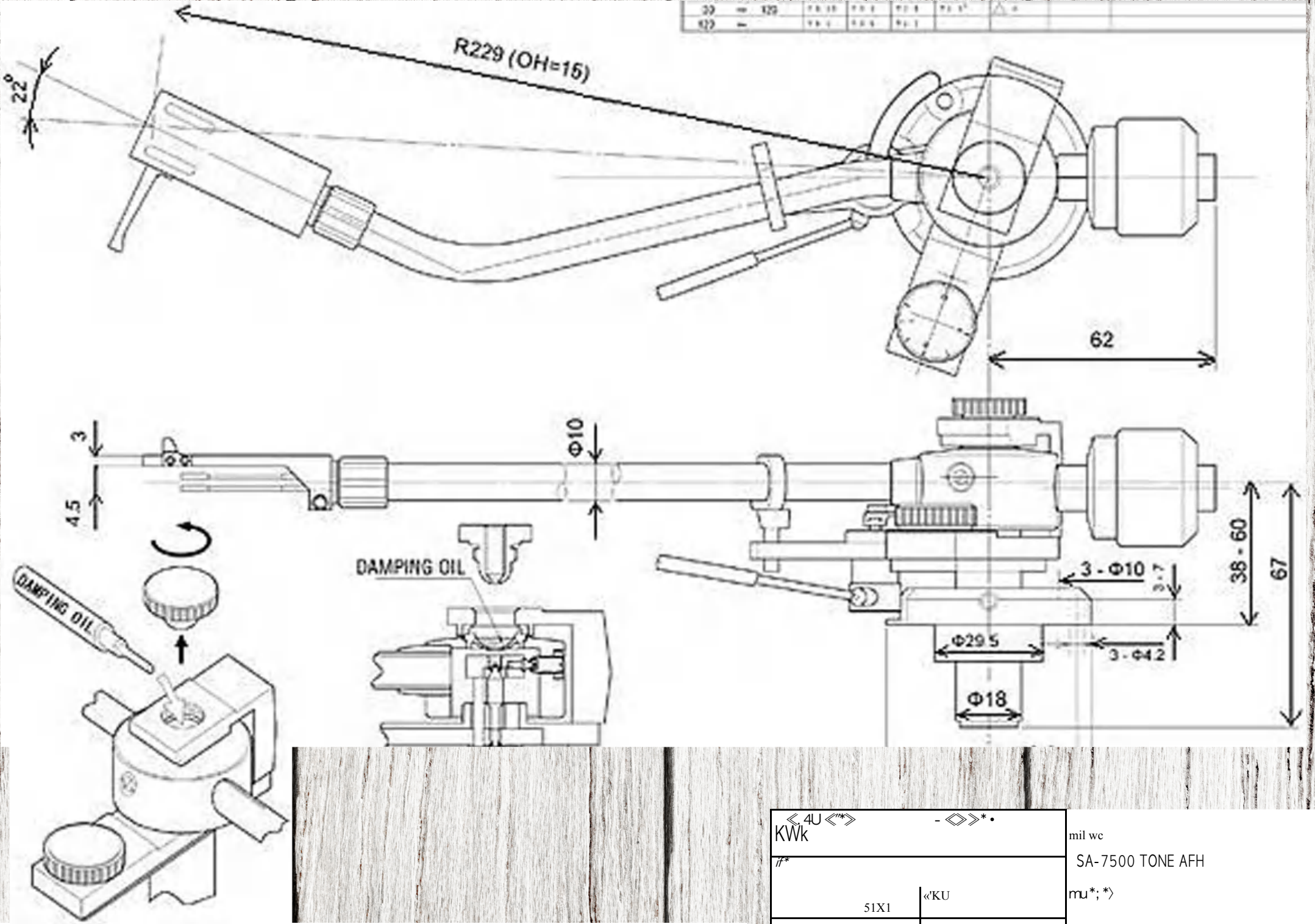

|     |   |     |       |      |      |      |      |      |      |
|-----|---|-----|-------|------|------|------|------|------|------|
| 39  | = | 129 | 10.15 | 10.1 | 10.1 | 10.1 | 10.1 | 10.1 | 10.1 |
| 429 | = | 129 | 10.15 | 10.1 | 10.1 | 10.1 | 10.1 | 10.1 | 10.1 |

Itt\*a\*

|              |  |                                     |
|--------------|--|-------------------------------------|
| KWk          |  | mil we                              |
| 51X1         |  | SA-7500 TONE AFH                    |
| MI           |  | mu*, *)                             |
| Jill m'X* 11 |  | <b>JELCO</b> CHIKAHA JEWEL CO.,LTD. |



Loud and Proud

HIFIGOTEBORG.se a

LAD

WANT TO RELAX TO BEAUTIFUL  
MUSIC

**WELCOME**

WE HAVE GOOD HIFI AT YOUR  
SERVICE

PLEASE WAIT HERE & A MEMBER  
OF OUR TEAM WILL BE WITH  
YOU SHORTLY.

Or press finger HERE