



SERVICE MANUAL
FOR
SUBWOOFER B2-50

LIST OF CONTENTS

1. TECHNICAL DESCRIPTION
 - 1.1 Power Supply
 - 1.2 Automatic ON/OFF
 - 1.3 Input Stage
 - 1.4 Filters
 - 1.5 Ace-Bass Amplifier
 - 1.6 Power Amplifier

2. TROUBLE SHOOTING TIPS
 - 2.1 B2-50 Does Not Work
 - 2.2 Fuses F501, F502 Blow
 - 2.3 Automatic ON/OFF Faulty
 - 2.4 B2-50 Goes On and Off Repeatedly with no signal in.

3. ADJUSTMENTS
 - 3.1 Bias Adjustment in Power Amplifier
 - 3.2 Negative Output Resistance (R_s) in Ace-Bass Amplifier

4. SPARE PARTS

5. ENCLOSURES
 - 5.1 Circuit Diagram 2-125010
 - 5.2 Component Layout 3-125004

1. TECHNICAL DESCRIPTION

The theoretical Background for the Ace-Bass principle used in Subwoofer B2-50 is described in AES Preprint #1381.

The functions described below are separated by dotted lines on the Circuit Diagram.

1.1 Power Supply

The primary of the power transformer is always connected to the power cord via a voltage selector and a power fuse (5.0A slow at 117 V, 2.5A slow at 220-250 V). The idle current in this transformer is very low (approx. 25mA at 117 V supply).

The center tapped secondary winding supplies the Automatic ON/OFF via two diodes D201, D202, and a double rectifier D101 via a DPST switch K101. This switch is operated by a relay in the Automatic ON/OFF circuits.

Rectifier D101 supplies +- 40 V to the Power Amplifier, and also stabilized +- 15 V via voltage regulators, V101, V103.

It is very important that the -15 V tracks the +15 V accurately when power is switched on or off. Mistracking can cause transients or oscillations in the electronic circuits.

To maintain tracking of the +15 V and -15 V when power is disconnected, the +40 V must decay faster than the -40 V. For this reason the Power Amplifier is built to always maintain a small positive offset voltage (10-100mV) on its output terminals under operating conditions.

If the B2-50 is tested without any load on the Power Amplifier, or with fuses F501, F502 removed, the balance between +15 V and -15 V may be upset during on/off switching. In such cases the operational amplifiers may start oscillating when power is disconnected, so that Automatic ON is actuated. This is normal under these conditions, and the electronics will not be damaged.

1.2 Automatic ON/OFF

This circuit is powered via diodes D201, D202 and capacitor C201.

The power transformer and the Automatic ON/OFF circuit are powered at all times when B2-50 is plugged in to a live outlet.

The other circuits in B2-50 are powered only when relay K101 is actuated.

The audio signal on left channel is sensed by operational amplifier Z201 (3, 2, 1) which acts as an amplifier with gain 5,000 at 500Hz. The amplified voltage (point H) is limited to +7.0 V and -0,7 V by zener diode D208.

Operational amplifier Z201 (6, 5, 7) and transistor V201 work as a Schmitt trigger with ON level 7 V and OFF level 5 V. The input (pin 5) senses the voltage from Z201 (3, 2, 1) after rectification in D209 and capacitor C206.

Transistor V201 drives relay K101 and a red LED indicating "ON". When toggle switch 5201 is in position "AUTO", relay K101 is de-energized about 5 minutes after the audio signal on left channel input disappears. The time delay is determined by C206 and R210. (During testing R210 may be shunted by 100 kohm, so delay time is reduced).

When toggle switch 5201 is in position "ON" the sensing circuits are bypassed, and relay K101 is energized as soon as B2-50 is plugged in to a live outlet.

Temperature sensor TS3-85 senses the temperature of the Power Amplifier heatsink. If this temperature becomes too high, the resistance in TS3-85 drops to a low value, and relay K101 is de-energized.

1.3 Input Stage

The audio signals on DIN plug J303 pin 1 (left channel) and pin 4 (right channel) pass through variable high pass filters formed by C303, R315, R317 and C304 R316, R317 and buffer amplifiers Z301 (5, 6, 7) and Z301 (3, 2, 1) to DIN plug J303 pins 3 and 5. From pins 3 and 5, they can be returned to an external power amplifier driving the satellite speakers. The buffer amplifiers provide low output impedance, so cable capacitances will not affect the treble response.

The audio signals on DIN plug J303 pins 1 and 4, or alternatively on speaker plugs J301, J304, are summed by resistors R318, R319 into a first active low pass filter with kneepoint 138Hz and 8dB gain at 100Hz (when channels are in parallel).

The signal from the first low pass filter is passed via a volume control R322 to a second amplifier stage Z301 (10, 9, 8) with 17dB gain.

1.4 Filter

The signal from Z301 pin 8 (test point C) passes a variable low pass filter including R401, R402, R403, C401, C402 and Z401 (10, 9, 8), and then on to a fixed high pass filter with kneepoint 22.8Hz. The output terminal is test point (E).

Remaining components in the filter circuits are part of the Ace-Bass amplifier, and is described in section 1.5.

1.5 Ace-Bass Circuits

The Power Amplifier together with Z401 (1, 2, 3) and Z401 (12, 13, 14) form the Ace-Bass amplifier, which can be represented by the diagram below.

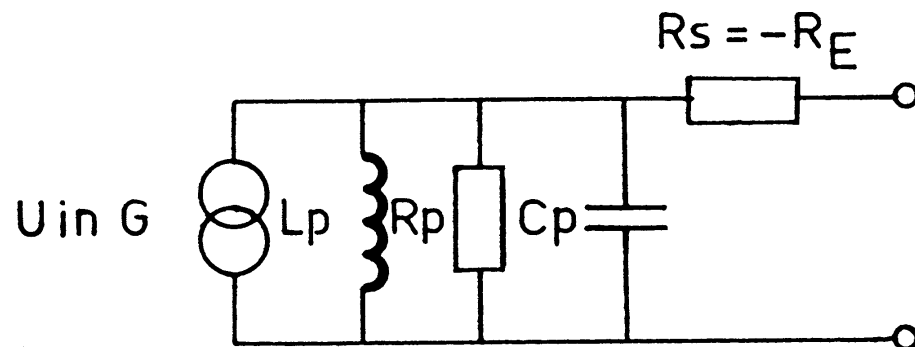

R418 and Z401 (12, 13, 14) sense the current through the drivers. The voltage in test point (J) equals the driver current (1V/1A).

Z401 (2, 3, 1) works as an active bandpass filter, and also sums the signals in test points (E) and (J).

The Power Amplifier is of inverting type, and also acts as a summing amplifier, adding signals (F) and (J).

Part of the driver current signal is fed back positively through the Power Amplifier, which gives the Power Amplifier a negative output resistance R_s . The amount of positive feedback, and thereby, the value of R_s , can be adjusted by trimpot R_{rs} .

The parallel circuit L_p , R_p , C_p in the Ace-Bass amplifier is accomplished through negative feedback of the driver current signal via the bandpass filter, (Z401 (2, 3, 1)).

1.6 Power Amplifier

The input signal to the Power Amplifier is DC decoupled by capacitor C414, and is amplified linearly to the output (test point G).

The output signal is fed back negatively to the input via R511, C503.

When the output signal is large, negative feedback is also obtained via a diode - resistor network. The amplitude of the output signal is compared to the supply voltages (+40 V) in this network, and about 2 volts before clipping, the output signal is rounded off by the diode network so clipping will be soft.

The differential input stage (V503, V506) is supplied via a current generator (V504). Transistors V501, V502, V505 form a current mirror, so the output stages from V507, V509 are symmetrically driven.

The output stage is of triple darlington type with transistors V512-V517. AC gain is 1. V508 senses the temperature of the output transistors and assures constant bias current.

V510 and V511 filter the supply voltages to the input stages, removing hum and transients.

NOTE: If there is a "click" in B2-50 when it is switched on, the cause could be a short circuit in one of the transistors V510, V511.

2. TROUBLE SHOOTING TIPS

Use + pole of C104 or - pole of C103 as common point for measurements of DC or AC voltages.

2.1 B2-50 Does Not Work

Set toggle switch in ON position.

2.1-1 Check that LEDs AUTO and ON are lit.

2.1-2 Check power fuse and fuses F501, F502.

2.1-3 Check that DC voltages are OK.

+40 V : 40+-2 V

-40 V : 40+-2 V

+15 V : 15+-2 V

-15 V : 15+-2 V

2.1-4 To localize the fault, connect a signal generator to DIN plug J303, pins 1 and 4 in parallel. Set generator to 5mV, 100Hz sine wave. Turn "sensitivity" (R322) and "crossover frequency - subwoofer" (R402) to max. clockwise position. You should now measure as follows:

<u>Test Point</u>	<u>AC Volts</u>
A	approx. 5mV
B	approx. 13mV
C	approx. 95mV
D	approx. 90mV
E	approx. 90mV
F	approx. 40mV
G	approx. 0, 85V

} with drivers connected

2.2 Fuses F501, F502 Blow

- 2.2-1 Disconnect drivers, and repeat test per 2.1-4. Signal at test point (G) now should be around .5V.
- 2.2-2 Measure resistance of voice coils in drivers. Should be 6.6 ohm each, 3.3 ohm in parallel.

2.3 Automatic ON/OFF

This can also be checked with the same setup as in 2.1-4.

- 2.3-1 Set toggle switch in position "AUTO".
- 2.3-2 Signal at test point (H) should be clipped and measure 7 V peak to peak. (Oscilloscope) Signal at test point (I) should be about 20 V DC.
- 2.3-3 Shunt R210 by 100k ohm to shorten off - delay. Check that ON is actuated when signal from generator exceeds .5mV at 500Hz.

2.4 B2-50 Oscillates Between ON and OFF with no audio signal on input.

- 2.4-1 Check DC offset at test point (G). Should be between +10mV and +100mV.

If DC offset is outside these limits, fault can be in C414 or in the Power Amplifier. (See also section 1.1).

NOTE: If a large DC voltage has appeared at the output of the Power Amplifier (caused by a fault), C414 will probably be damaged, and it should be replaced.

3. ADJUSTMENTS

After certain repairs have been made in B2-50, the following adjustments must be performed.

3.1 Bias Adjustments in Power Amplifier

After repairs have been made in the Power Amplifier, the bias current must be readjusted.

Measure the voltage between emitters on V516 - V517 (no signal on input terminals of B2-50). Adjust trimpot Rqc (R525) till voltage reads 22mV. (This corresponds to a bias current of 50mA).

Make final adjustment after B2-50 has been ON for a few minutes, so the bias current has reached steady state value.

NOTE: When replacing power transistors, temperature sensor on V508, heatsink compound (and isolating shims) must be used.

3.2 Negative Output Resistance (R_s) in Ace-Bass Amplifier

Whenever a driver element or any of resistors R413 - R418 in the current sensing circuit has been replaced, the negative output resistance must be reset to equal the positive resistance of the parallel voice coils in the drivers.

- 3.2-1 Set jumper below trimpots in position "TRIM", and disconnect one speaker cable from the circuit board.
- 3.2-2 Connect a signal generator to the input (J303, pin 1 or pin 4), and an AC voltmeter across the amplifier output.
- 3.2-3 Set signal generator to 20.3 \pm .5Hz, and adjust level until voltmeter at amplifier output reads -16dBu (123mV).
- 3.2-4 Reconnect the speaker cable to the circuit board (so drivers are connected to amplifier output), and adjust trimpot R_s till voltmeter reads 0dBu (775mV).

NOTE 1: Voicecoils of drivers must be at room temperature when R_s is set.

NOTE 2: Voltages in 3.2-3 and 3.2-4 are correct. Negative output impedance of Ace-Bass amplifier makes output voltage larger when amplifier load increases.

3.2-5 Reset jumper in "RUN" position.

NOTE: Do not touch trimpot Ra (R410) This adjustment requires calibrated microphone equipment and can only be made at the factory. Ra only effects the sound pressure level at 20Hz. Change of one driver will cause maximum .5dB change in this level (typically less than .20dB), so no correction is required in the field.

3.2-6 Check for correct setting of Rrs as follows:

- Push the cone of forward facing driver inwards, and release it suddenly.
- Compare the movement of the cone with the curve below, and fine-adjust Rrs if required.

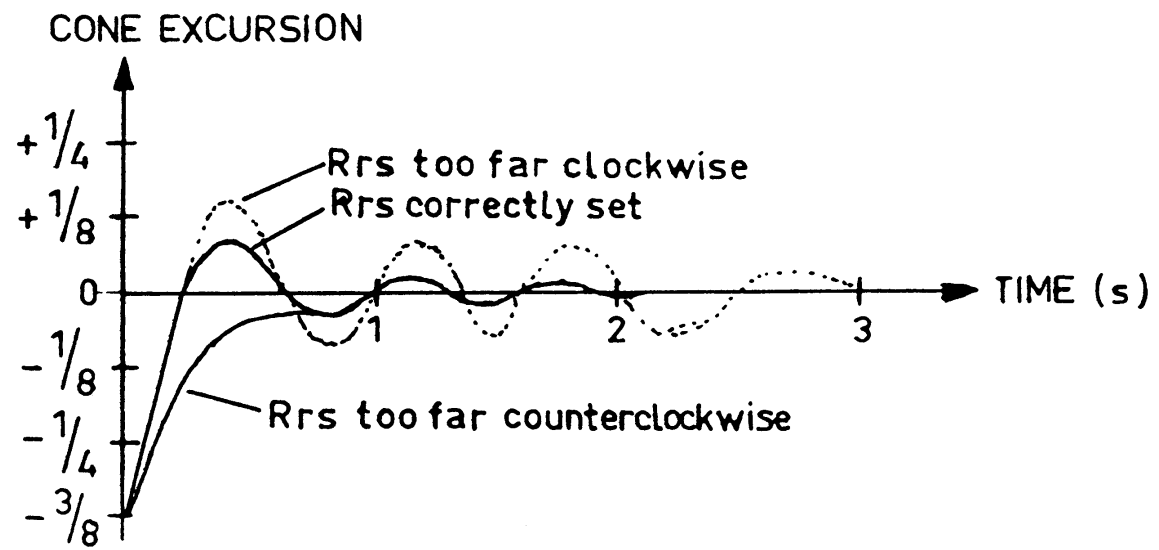

4. SPARE PARTS

Spare parts for B2-50 can be obtained from the factories, or from Distributors and Service Centers per separate listing.

When ordering spare parts, please refer to serial number of B2-50, and component number per diagram 2-125 010.

The document must not be copied, either completely or partially, without the written permission of Lövinger Elektronik AB. Any unauthorized copying or reproduction will lead to legal proceedings.

Material components reference to this instruction. Material components must be replaced with the same or an equivalent part.

Översiktligt bild, se alla komponenter. Översiktligt bild, se alla komponenter. Översiktligt bild, se alla komponenter.

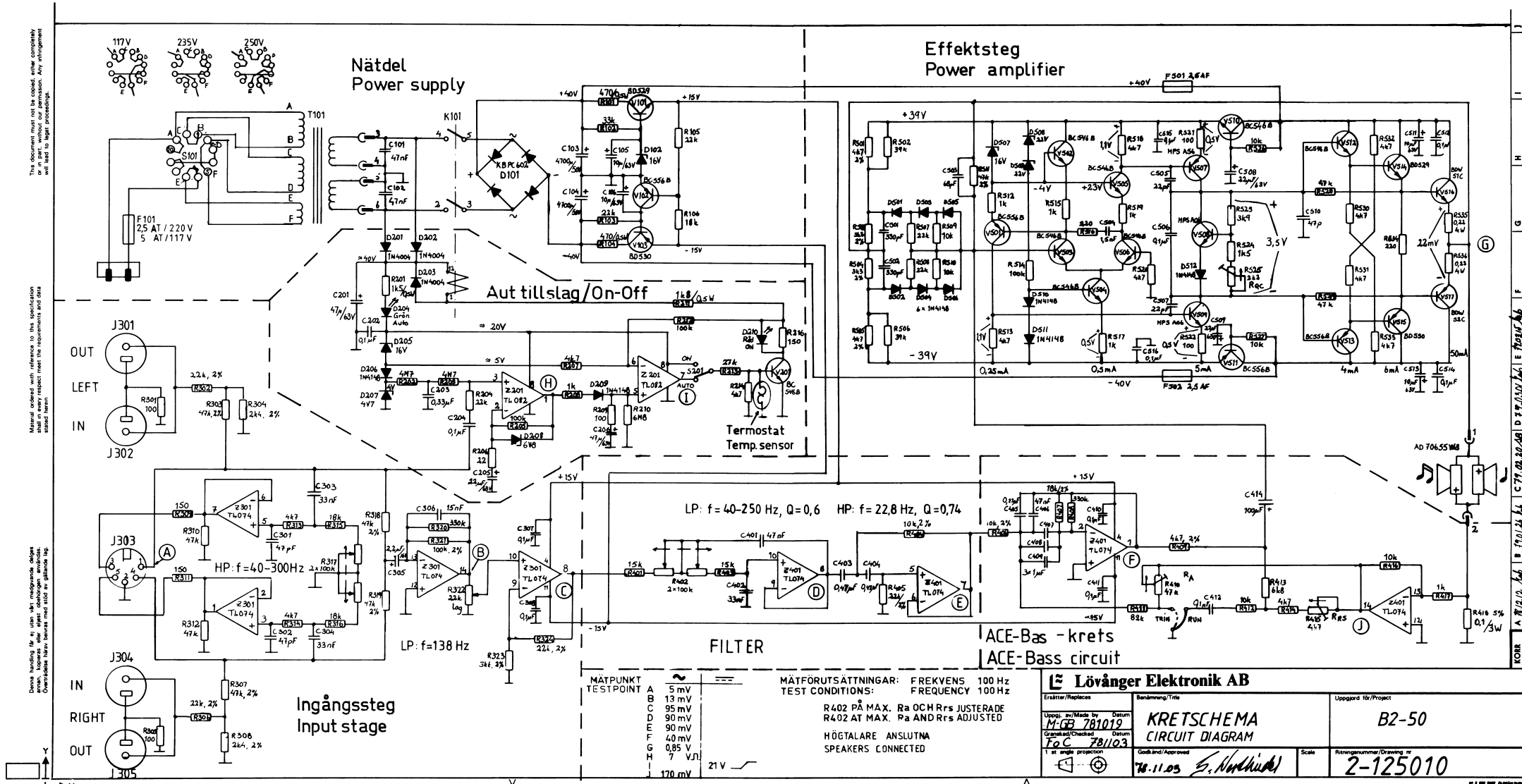

MÄTPUNKT TESTPOINT	V
A	5 mV
B	13 mV
C	95 mV
D	90 mV
E	90 mV
F	4.0 mV
G	0.85 V
H	7 V _{DC}
I	170 mV

MÄTFÖRUSÄTTNINGAR: FREKVENNS 100 Hz
 TEST CONDITIONS: FREQUENCY 100 Hz
 R402 PÅ MAX. R_a OCH R_rs JUSTERADE
 R402 AT MAX. R_a AND R_rs ADJUSTED
 HÖGTALARE ANSLUTNA
 SPEAKERS CONNECTED

Lövinger Elektronik AB
 Ersätter/Replaces: *[Blank]* Benämning/Title: **KRETSHEMA**
 Uppgett av/Drawn by: **M-GE 781019** Datum: *[Blank]*
 Granskad/Checked: **FoC 781103** Datum: *[Blank]*
 Godkänd/Approved: *[Signature]* Scale: **2-125010**

0002516

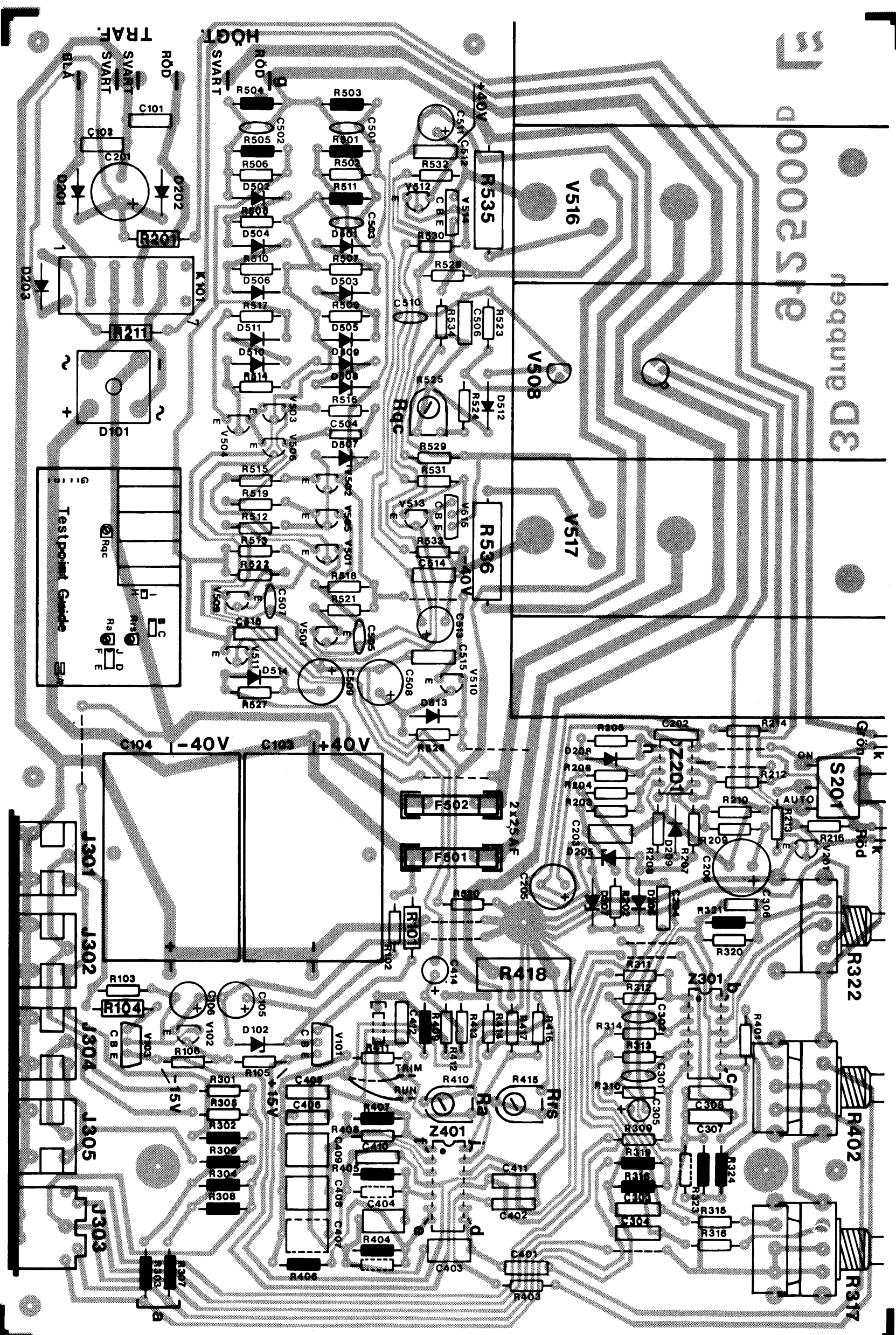

MK-rithn. 2-9125000

Långsigt Elektronik AB

SCREENFILM

B2-50

Datum: 781030 Skapad av: B.781030 Rikt: 781030	2:1 2-9125036
--	------------------

KORR | A 781107 SB | B 781212 MB

Loud and Proud

HIFIGOTEBORG.se a

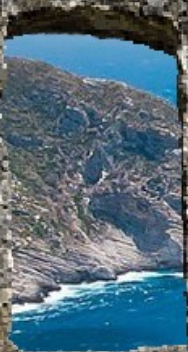

WANT TO RELAX TO BEAUTIFUL
MUSIC

WELCOME

WE HAVE GOOD HIFI AT YOUR
SERVICE

PLEASE WAIT HERE & A MEMBER
OF OUR TEAM WILL BE WITH
YOU SHORTLY.

Or press finger HERE