

PHASE III LOUDSPEAKER SYSTEM

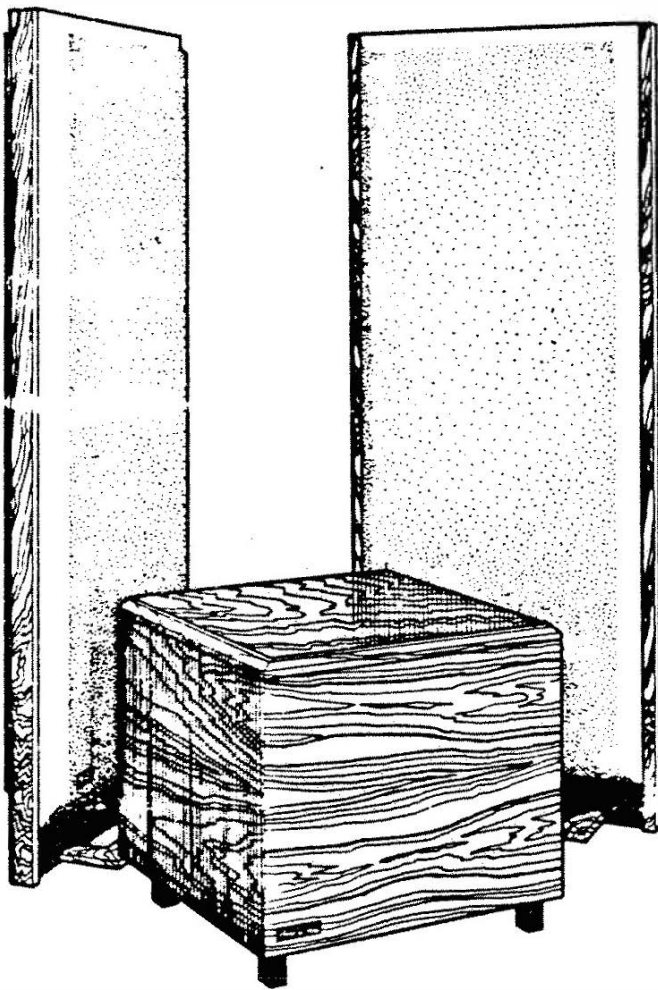

Service Manual

CONTENTS

1-0.	Specifications.....	3
2-0.	Circuit Description.....	4
3-0.	Schematics and Design History.....	5
4-0.	Motion Control Module Test & Alignment Procedure.....	18
5-0.	Speaker Panel & Bass Commode Test Procedure.....	20
6-0.	Parts List.....	21
7-0.	Service Bulletins.....	22

Prepared 4/78

1-0.

TECHNICAL
SPECIFICATIONS

Driver Compliment: 2 ea. 12" bass drivers
4 ea. 8" midbass drivers
4 ea. 4" midrange drivers
8 ea. 2" cone tweeters
2 ea. 1" soft-dome tweeters

Frequency Response: 24Hz to 20Kz \pm 3db

Nominal Impedance: 6 ohms

Maximum Power Input: 350 RMS watts per channel

Maximum Continuous Power Input: 100 RMS watts below 200Hz

Minimum Power Required: 50 RMS watts per channel

Sound Pressure Level: 80db at 1 meter on axis with 1 watt
of input at 1,000 HZ

Motion Control Module:

Input Impedance: 22K ohms

Output Impedance: less than 600 ohms

Maximum Output Voltage: 8 volts RMS

Distortion: less than 0.1%

Hum and Noise: less than 100 microvolts

2-0.

CIRCUIT DESCRIPTION
MOTION CONTROL MODULE

In sections B4 and D4 operational amplifiers Z1-C and Z1-D serve as active 12db/octave subsonic filters with high pass gain of 6db. The signal path then splits to section C3, ambience circuitry, and sections B3 and D3 which incorporate high frequency and midrange tone shaping circuits. Front panel-mounted switches S1-A and S1-B allow switchable high frequency response selection. Op amps Z2-A and Z2-B incorporate switchable midrange response through front panel-mounted switches S2-A and S2-B, and also low frequency through front panel-mounted switches S3-A and S3-B.

Z2-C and Z2-D in section 2 are output buffers with high frequency boost.

Z1-A in section C4 is a difference amplifier which supplies a weighted L-R signal to the left channel through Z2-A. Z1-B acts as an inverter buffer supplying a R-L signal to the right channel through Z2-B. The amount of ambience mix is governed by potentiometer R501, front panel-mounted.

Q1 and associated circuitry provides time delay output switching through relay K1. Response time is 1 to 2 seconds after turn-on and instantaneous at turn-off.

3-0.

SCHEMATICS AND DESIGN HISTORY

For Panel Serial Numbers 1736 and Earlier:

- Diagram III-1: Phase III System Schematic
- III-2: Crossover Assembly Layout
- III-3: Panel Assembly Layout
- III-4: Motion Control Module Schematic
- III-5: Motion Control Module Assembly Layout
(also see Diagram III-11)

For Panel Serial Numbers 1737 and Forward:

- Diagram III-6: Phase III System Schematic
- III-7: Crossover Assembly Layout
- III-8: Panel Assembly Layout
- III-9: Motion Control Module Schematic
- III-10: Motion Control Module Assembly Layout

For All Panel Serial Numbers:

- Diagram III-11: Motion Control Module Chassis Transformer Layout
- III-12: Bass Commode Assembly Layout

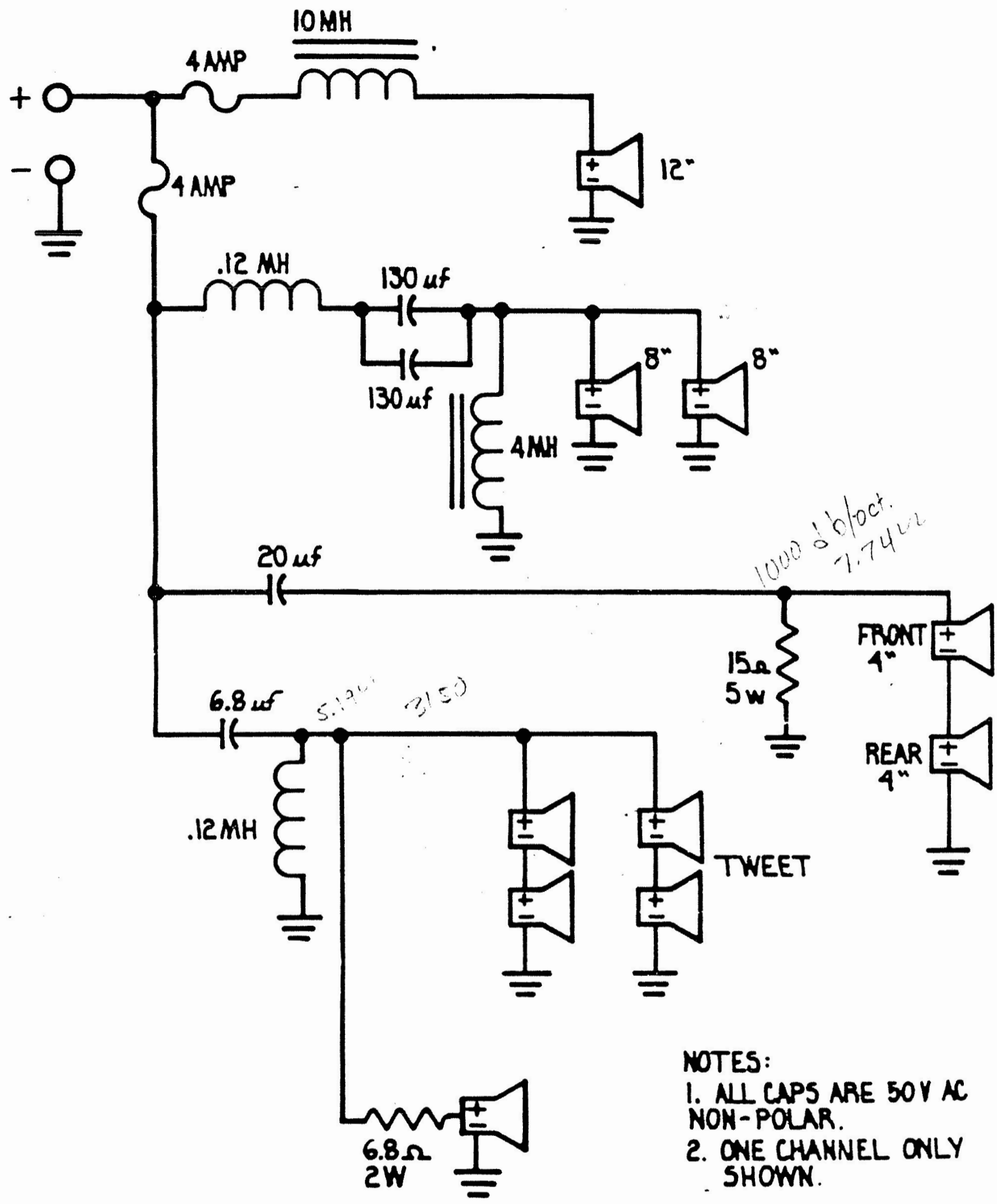

NOTES:
 1. ALL CAPS ARE 50V AC NON-POLAR.
 2. ONE CHANNEL ONLY SHOWN.

PHASE LINEAR

SCHMATIC PHASE III SPEAKER

DRAWN	RAT	1-19-78
CHECKED		
APPROVED		

PANEL SERIAL NUMBER 1736 AND EARLIER

REV	
-----	--

210-0072-0

REVISIONS				
LTR	DESCRIPTION	BY	DATE	APPROVED
A	1. REVISED SHEET 1	M.D.C.	6-9-76	
B	1. EXTENSIVELY REVISED CROSSOVER	M.D.C.	7-19-76	
C	1. EXTENSIVELY REVISED CROSSOVER	M.D.C.	8-5-76	
D	1. 2N B4 ADDED 2 ND (48) TO PICTURE	M.D.C.	10-22-76	

NO CONNECTION AT THIS POINT
 CONNECTING POINT FOR GREEN WIRE (REF)
 CONNECTING POINT FOR 3 BLACK WIRES (REF)
 CONNECTING POINT FOR WHITE WIRE (REF)
 CONNECTING POINT FOR RED WIRE (REF)
 CONNECTING POINT FOR BLUE WIRE (REF)

.125 DIA. HOLE
 (91) 3 PLACES

.28 TYP
 4 PLACES

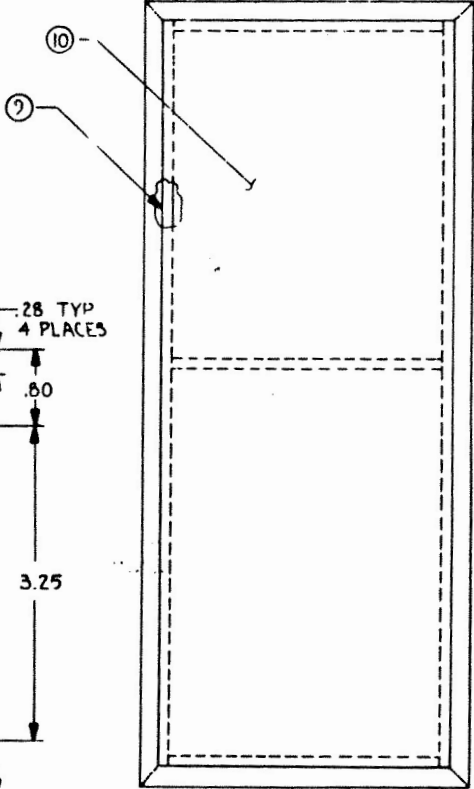

(11) GRILL FRAME ASSY
 210-0086-0

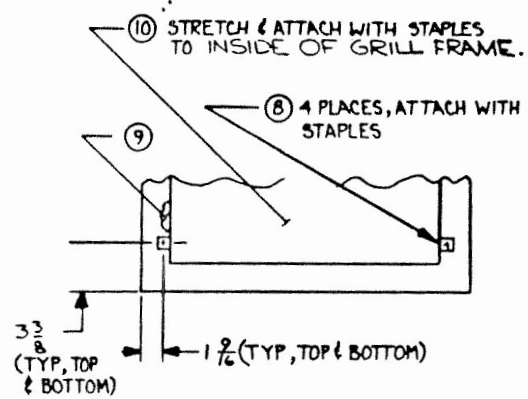

PAINTED SURFACE THIS SIDE

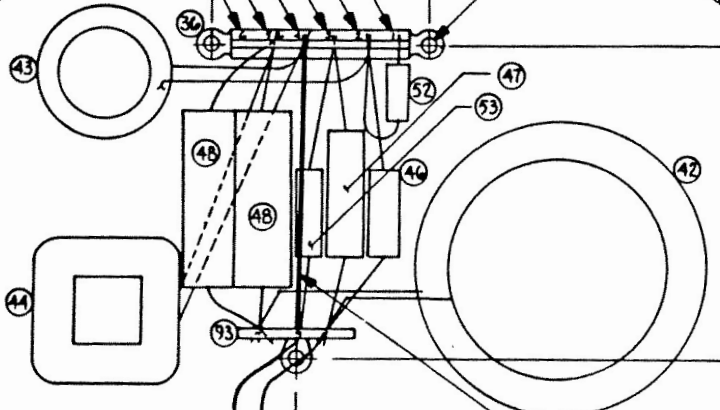

(99) RED WIRE TO RED BINDING POST (59)

(100) BLACK WIRE THRU FUSE BLOCK (37) TO BLACK BINDING POST (56)

#18 SOLID TINNED JUMPER WIRE

(29) CROSSOVER NETWORK ASSY

UNLESS OTHERWISE SPECIFIED DIM. AND TOL. ARE IN INCHES AND SHALL BE INTERPRETED PER (ANSI) Y14.5-1966.		DRAWN	MIKE CHANDLER	4/27/76
TOLERANCES ARE:		CHECKED	O. Anderson	5/17/76
1 DEC ± .1	3 DEC ± .005	APPROVED		/ /
2 DEC ± .01	4 DEC ± .0005	RELEASE STATUS		
ANGLES ± 0° 30'		PROJ.	/ /	
REMOVE BURRS, BRK SHARP EDGES MACH SURFACES 100%		FINAL	/ /	
MATL:			/ /	
FINISH:			/ /	
HT. TREAT:			/ /	
DO NOT SCALE DWG.		SCALE	NONE	

<i>Phase Linear</i>			
ASSY, SPEAKER SYSTEM			
ORION III			
Ser #1736 and earlier			
SIZE	C	DWG. NO.	210-0072-0
REV. D		SHEET 1 OF 1	

ATTACHMENTS 012345

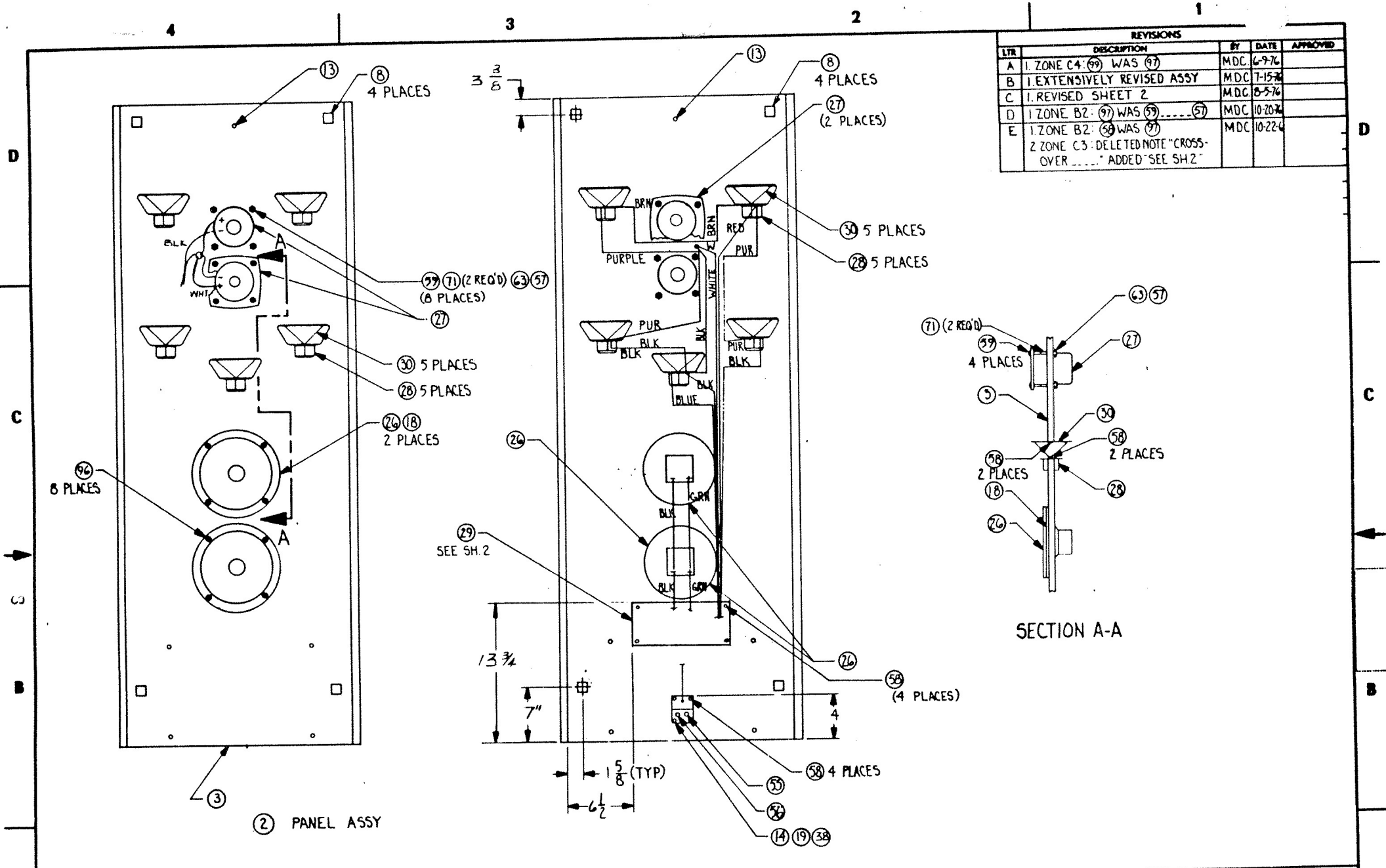

REVISIONS				
LTR	DESCRIPTION	BY	DATE	APPROVED
A	1. ZONE C4: (99) WAS (97)	MDC	6-9-76	
B	1. EXTENSIVELY REVISED ASSY	MDC	7-15-76	
C	1. REVISED SHEET 2	MDC	8-5-76	
D	1. ZONE B2: (97) WAS (99).....(57)	MDC	10-20-76	
E	1. ZONE B2: (59) WAS (97) 2. ZONE C3: DELETED NOTE "CROSS-OVER". ADDED "SEE SH. 2"	MDC	10-22-76	

UNLESS OTHERWISE SPECIFIED DIM. AND TOL. ARE IN INCHES AND SHALL BE INTERPRETED PER (ANSI) Y14.5-1964. TOLERANCES ARE: 1 DEC ±.1 3 DEC ±.005 2 DEC ±.01 4 DEC ±.0005 ANGLES ±1° 30' REMOVE BURRS, BRK SHARP EDGES MACH SURFACES ✓ MATL: FINISH: HT. TREAT:	DRAWN MIKE CHANDLER 4/23/76 CHECKED P. Landon 5/17/76 APPROVED / /	<i>Phase Linear</i>	
	RELEASE STATUS PREL. / / FINAL / /		ASSY, SPEAKER SYSTEM, "PHOME" III Ser #1736 and earlier
	DO NOT SCALE DWG.		
	SCALE NONE		SHEET 1 OF 1

DIAGRAM TTT-3

REVISIONS			
LTR	DESCRIPTION	BY	DATE

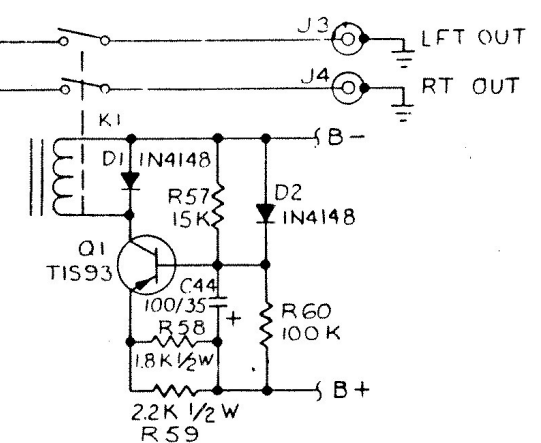
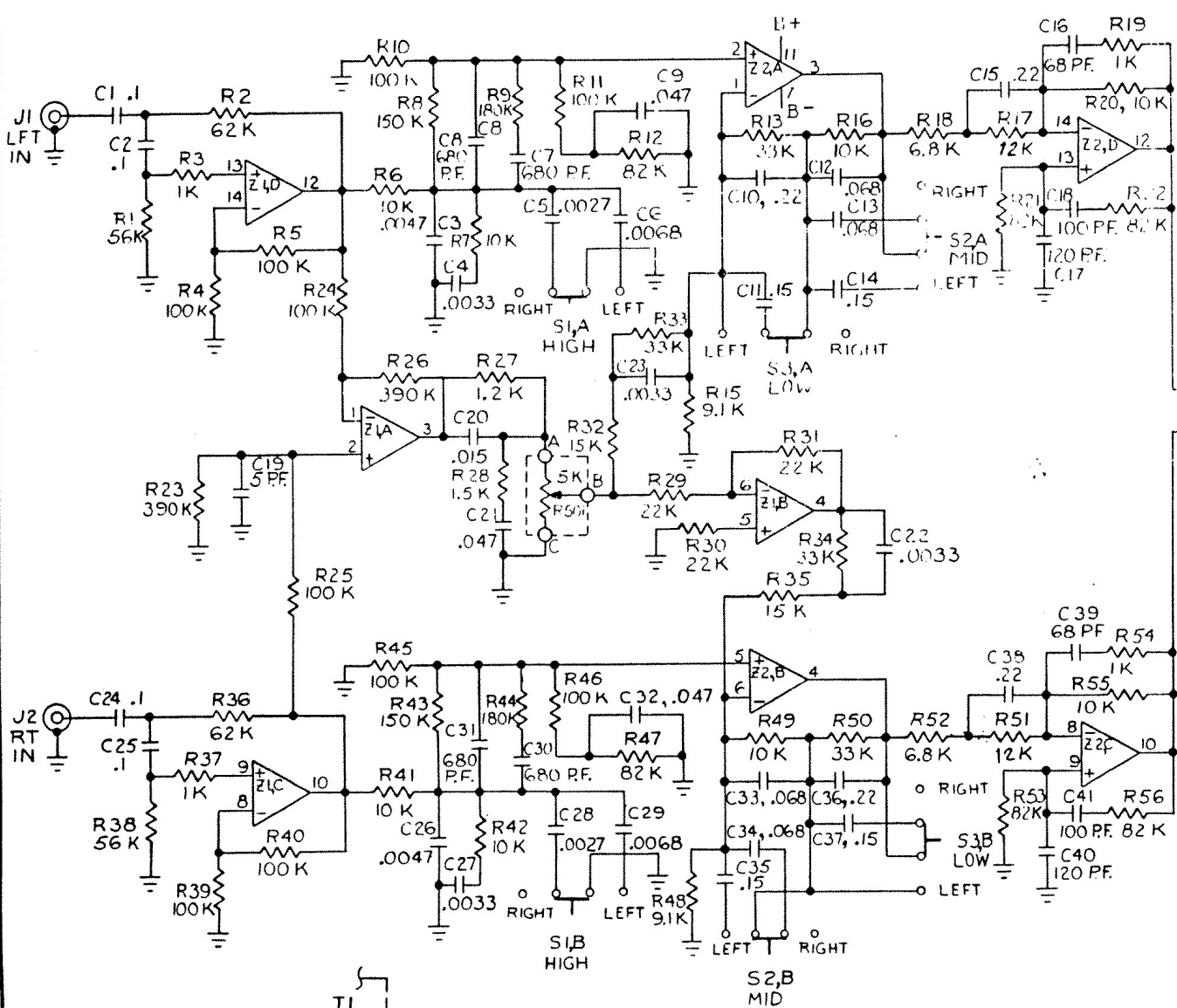

NOTES: UNLESS SPECIFIED OTHERWISE
 1. ALL RESISTORS 1/4W, ±5% VALUE IN OHMS
 2. ALL CAPACITORS IN UF / 100 V

Revision shown is for speaker panel serial numbers 1736 and earlier.

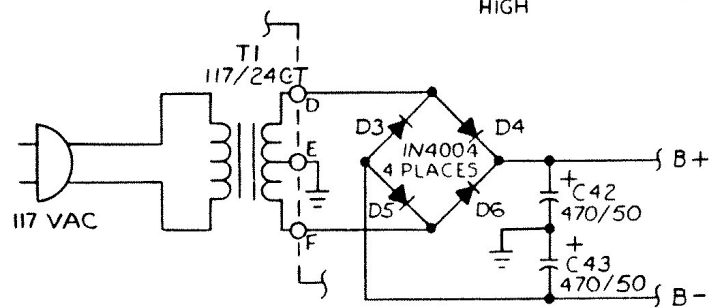

UNLESS OTHERWISE SPECIFIED DIM. AND TOL. ARE IN INCHES AND SHALL BE INTERPRETED PER (ANSI) Y14.5-1966. TOLERANCES ARE: 1 DEC ±.1 3 DEC ±.008 2 DEC ±.01 4 DEC ±.0008 ANGLES ±1° 30'	DRAWN	E REDDEN	11/29/76	<i>Phase Linear</i>	
	CHECKED	SMK	12/6/76		
	APPROVED	AK	12/6/76		
	REMOVE BURRS, DRX SHARP EDGES MACH SURFACES 1/16"	PREL.		1/1	PCB ASSY SCHEMATIC PL25 SPEAKER EQUALIZER PIII
MATL:	FINAL		1/1		
FINISH:			1/1	SIZE	DWG. NO. 210-0071-0
HT. TREAT:			1/1	C	
	DO NOT SCALE DWG.		SCALE: —	SHEET 2 OF 2	

ATTACHMENTS 012345

REVISIONS				
LTR	DESCRIPTION	BY	DATE	APPROVED
E	NEW PCB COMPLETELY REWORK	SMK	11/24	

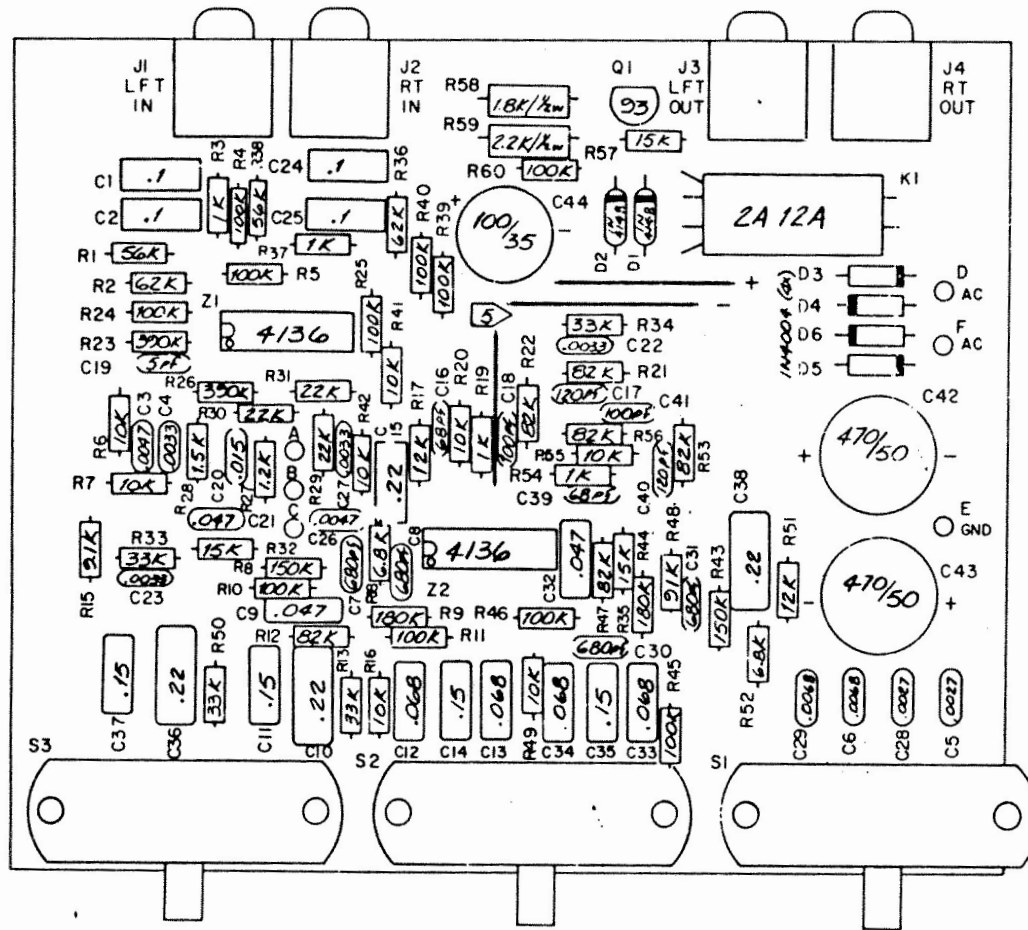

- NOTES; UNLESS OTHERWISE SPECIFIED**
1. FOR SCHEMATIC SEE SHT 2 OF 2
 2. ALL RESISTORS 1/4W 5% VALUE IN OHMS
 3. CAPACITORS IN AL (MFD)
 4. C17, 18, 40, 41 ARE 10%
 5. JUMPER 22AWG SOLID WHT PIN 124-0082-0

Revision shown is for speaker panel serial numbers 1736 and earlier.

PL25 REVE 06612

UNLESS OTHERWISE SPECIFIED DIM. AND TOL. ARE IN INCHES AND SHALL BE INTERPRETED PER (ANSI) Y14.5-1966. TOLERANCES ARE: 1 DEC ±: .1 3 DEC ±: .006 2 DEC ±: .01 4 DEC ±: .0008 ANGLES ±: 0° 30'	DRAWN: <i>SMK</i> 11/30/76	Phase Linear PCB ASSY, PL25 SPEAKER EQUALIZER	
	CHECKED: <i>M. F.</i> 11/30/76		
REMOVE BURRS. BRK SHARP EDGES MACH SURFACES 1/8"	RELEASE STATUS		SIZE: C DWG. NO. 210-00710 E REV.
FINISH:	FRIL:	FRNL:	
HT. TREAT:	DO NOT SCALE DWG.		SCALE: SHEET 1 OF 2

DIAGRAM TII-5

ATTACHMENT 345

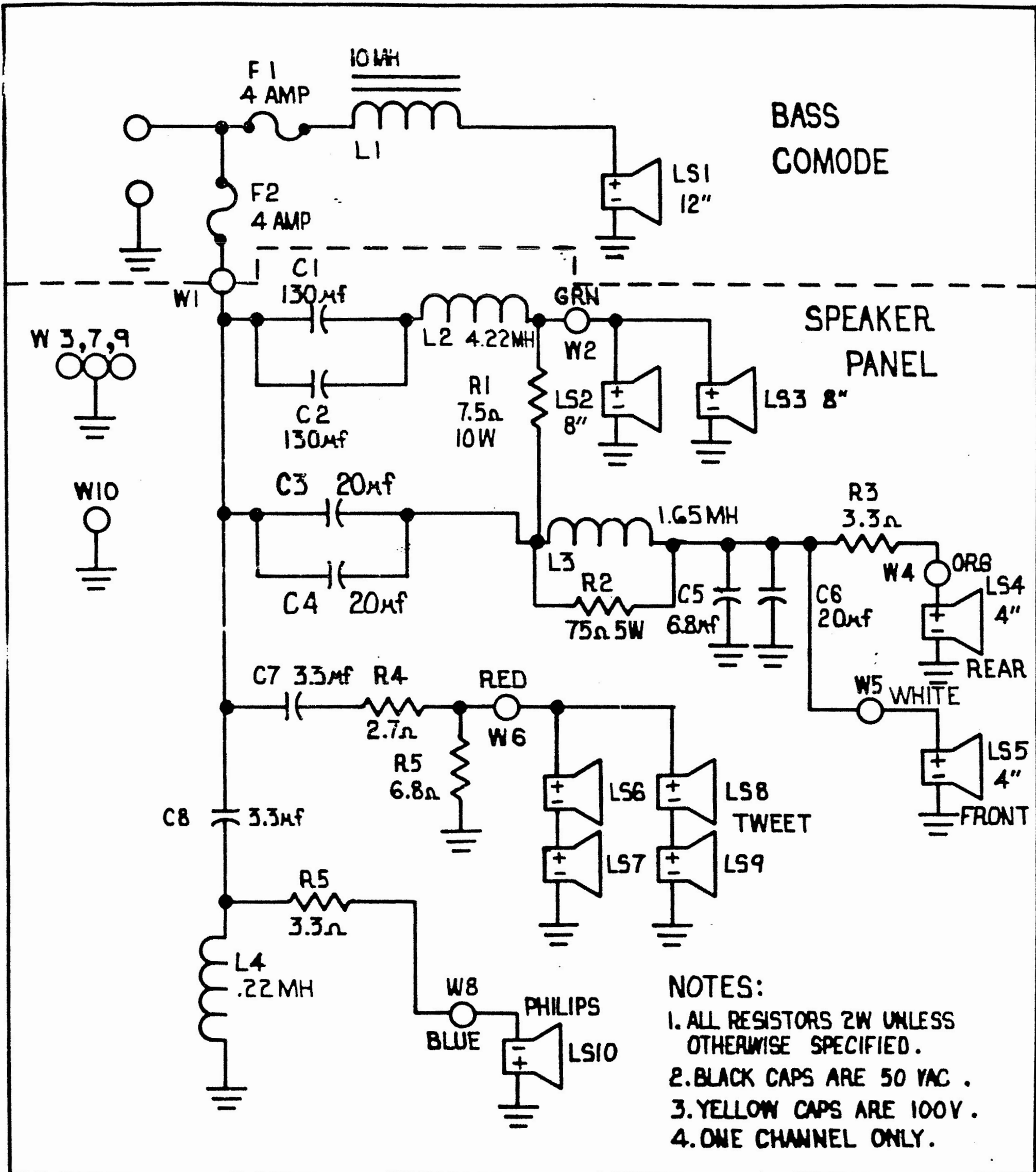

PHASE LINEAR			SCHEMATIC	
PHASE III			SPEAKER	
DRAWN	R. CLARK	11-22-77		
CHECKED				
APPROVED			Serial Number 1736 Forward	
			REV	

REVISIONS	
NO.	DESCRIPTION

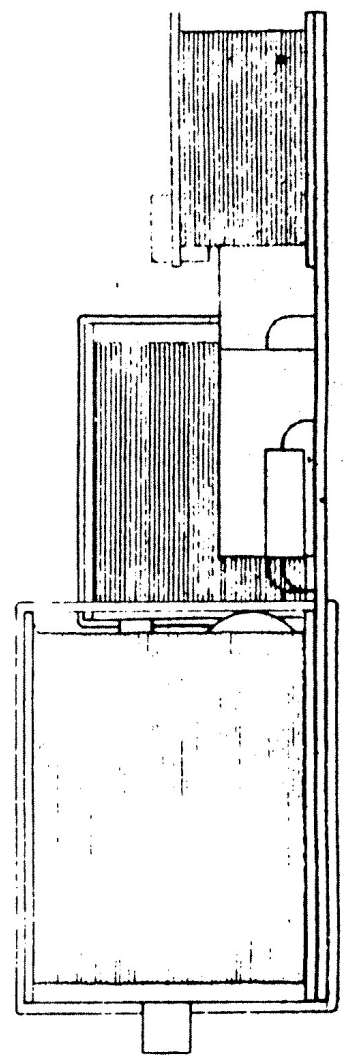
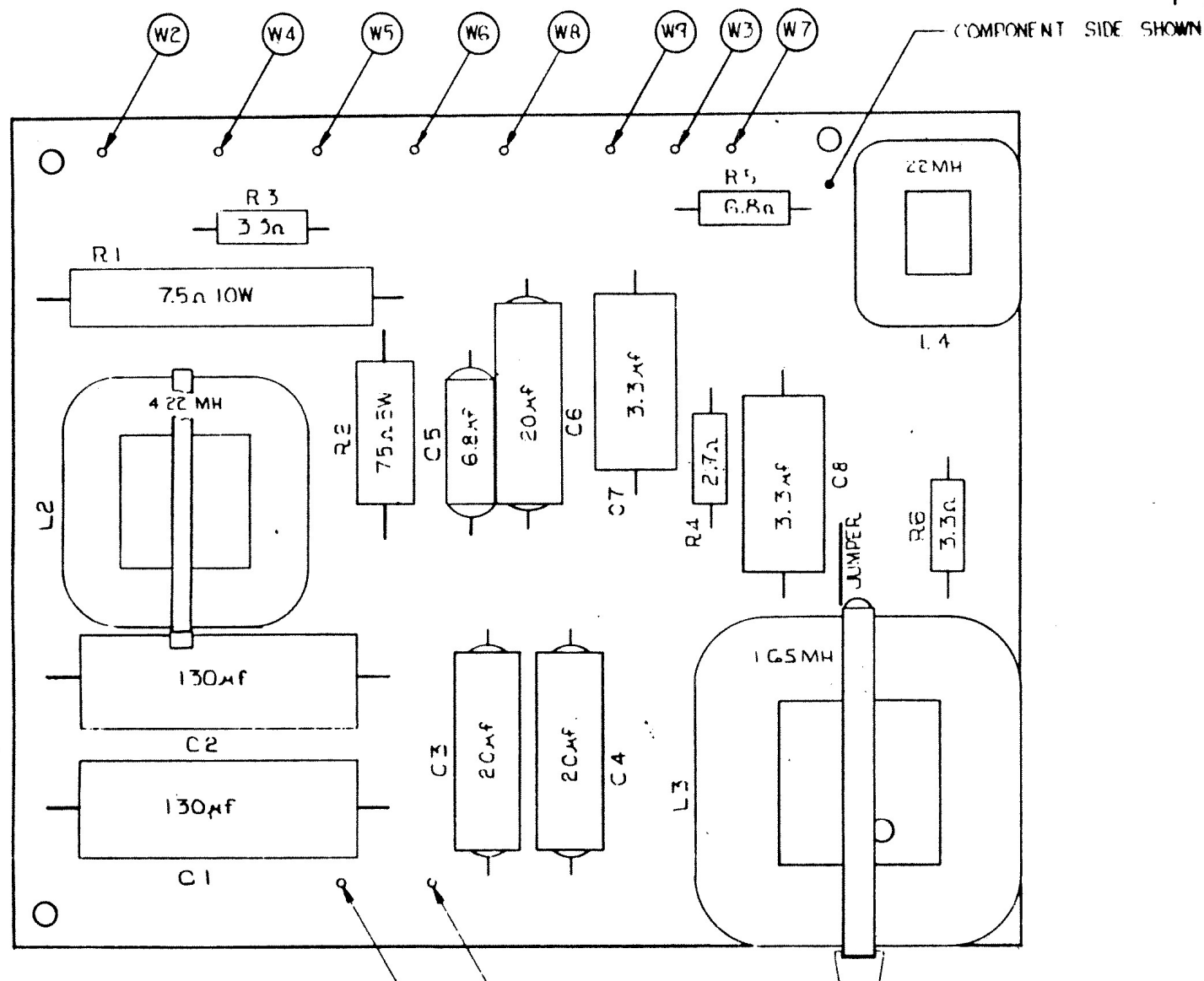

- NOTES:
1. ALL RESISTORS 2W UNLESS OTHERWISE SPECIFIED.
 2. BLACK CAPACITORS ARE 50 VAC.
 3. YELLOW CAPACITORS ARE 100 VAC.

UNLESS OTHERWISE SPECIFIED DIM. AND TOL. ARE IN INCHES AND SHALL BE INTERPRETED PER (ANSI) Y14.5-1964. TOLERANCES ARE: 1 DEC ± .1 3 DEC ± .005 2 DEC ± .01 4 DEC ± .0005 ANGLES ± 9° 30'	DRAWN	R. CLARK	11/25/77
	CHECKED		/ /
	APPROVED		/ /
	RELEASE STATUS		
REMOVE BURRS, BRK SHARP EDGES MACH SURFACES ✓	PREL.		/ /
MAT'L:	FINAL		/ /
FINISH:			/ /
HT. TREAT:			/ /
	DO NOT SCALE DWG.		

<i>Phase Linear</i>	
PCB ASSEMBLY	
PHASE III SPEAKER	
SIZE	DWG. NO.
C	210-0077-0
SCALE: E.A.	SHEET 3 OF 3



Panel, Serial #1736 Forward

DIAGRAM III-8

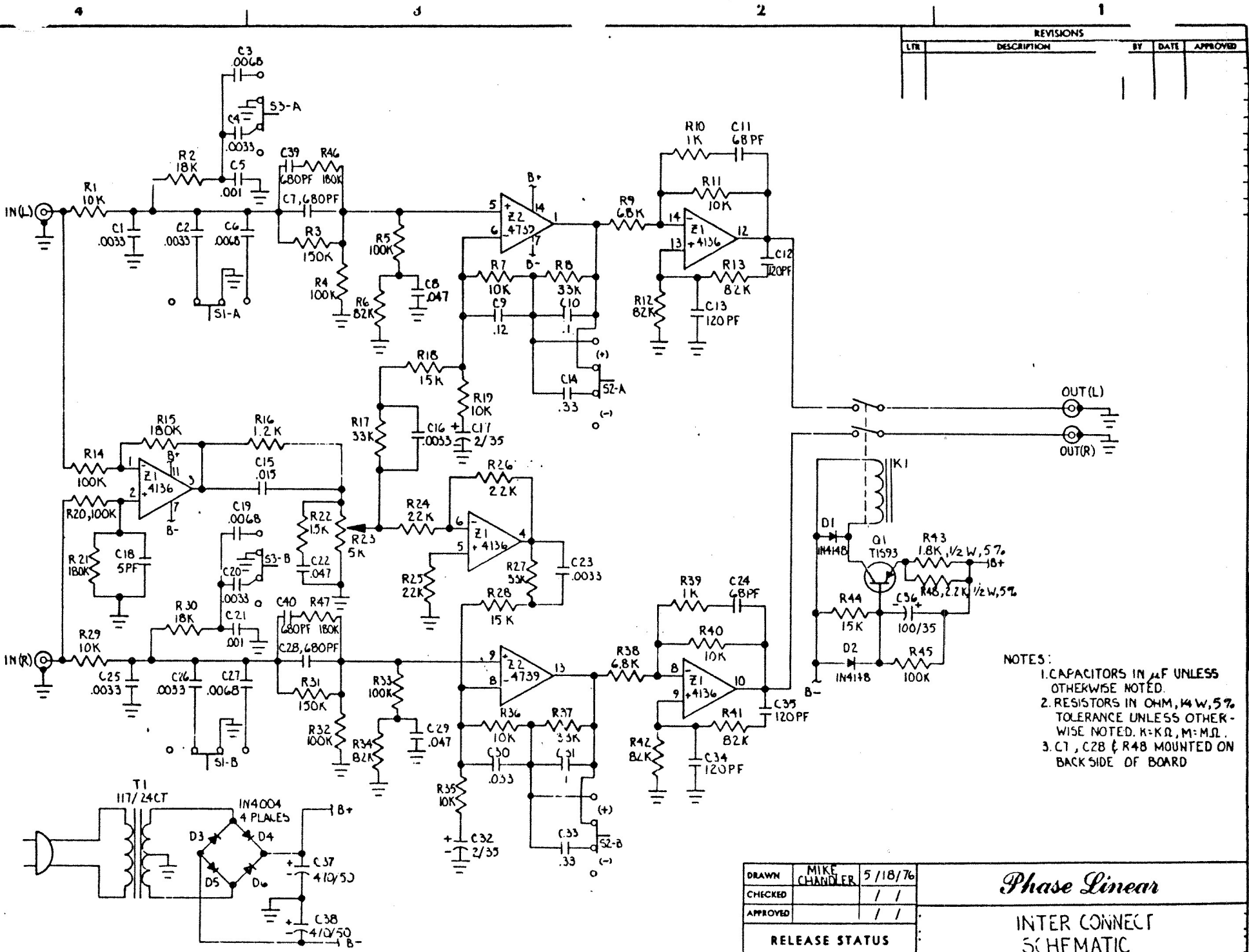

REVISIONS			
LTR	DESCRIPTION	BY	DATE

- NOTES:
1. CAPACITORS IN μ F UNLESS OTHERWISE NOTED.
 2. RESISTORS IN OHM, 1/2 W, 5% TOLERANCE UNLESS OTHERWISE NOTED. K=K Ω , M=M Ω .
 3. C1, C28 & R48 MOUNTED ON BACK SIDE OF BOARD

DRAWN	MIKE CHANDLER	5/18/76
CHECKED		/ /
APPROVED		/ /
RELEASE STATUS		
PREL		/ /
FINAL		/ /
		/ /
		/ /

<i>Phase Linear</i>		
INTER CONNECT SCHEMATIC PIII EQUALIZER		
SIZE	DWG. NO.	REV.
C	402634	C
DO NOT SCALE DWG.		SHEET 1 OF 1

DIAGRAM TTT-9

REVISIONS			
LTR	DESCRIPTION	BY	DATE

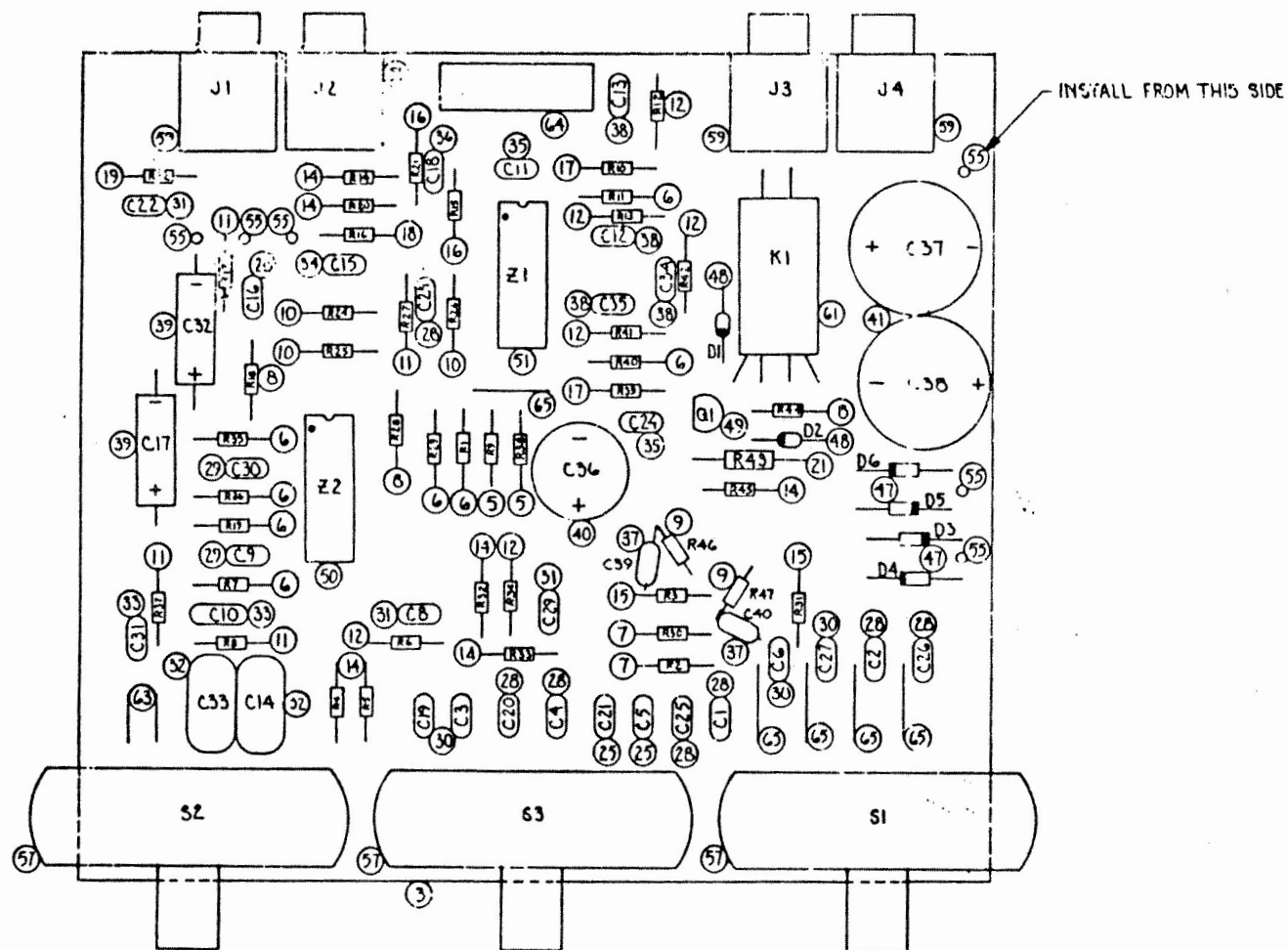

O4 ASSY PL25 41600

- 01-SAME AS 02 EXCEPT C1 & C25 ARE .001 & C14 & C25 ARE .47
 02-SAME AS 03 EXCEPT C5 & C21 ARE .0033 AND ALL JUMPER WIRES .4 LG
 03-SAME AS 04 EXCEPT C1 & C25 ARE .0018, C2 & C26 ARE .0015, C6 & C27 ARE .0033,
 C9 & C30 ARE .033, C12, C13, C34 & C35 ARE 100 PF, R15 & R21 ARE 220K, C7 & C28 ARE ON
 TOP OF BOARD & R43 IS 1K, R2W
 04-SHOWN

NOTES:

- FOR SCHEMATIC SEE DWG 402634
- C7 & C28 IN SAME LOCATION ON BACK SIDE OF BOARD
- R48 MOUNTED ON BACK SIDE OF BOARD PARALLEL TO R43

UNLESS OTHERWISE SPECIFIED DIM. AND TOL. ARE IN INCHES AND SHALL BE INTERPRETED PER (ANSI) Y14.5-1966. TOLERANCES ARE: 1 DEC ±: .1 3 DEC ±: .008 2 DEC ±: .01 4 DEC ±: .006 ANGLES ±: # 37 REMOVE BURRS, BRK SHARP EDGES MACH SURFACES 1/2"	DRAWN	MIKE CHANDLER	5/18/76	<i>Phase Linear</i>	
	CHECKED	✓	5/29/76		
	APPROVED		/ /	PCB. ASSY, PL25 SPEAKER EQUALIZER P III	
	RELEASE STATUS				
MATL:	PREL.	/ /	SIZE	DWG. NO.	REV.
FINISH:	FINAL	/ /	C	402626	C
HT. TREAT:		/ /	DO NOT SCALE DWG.	SCALE NONE	SHEET 1 OF 1

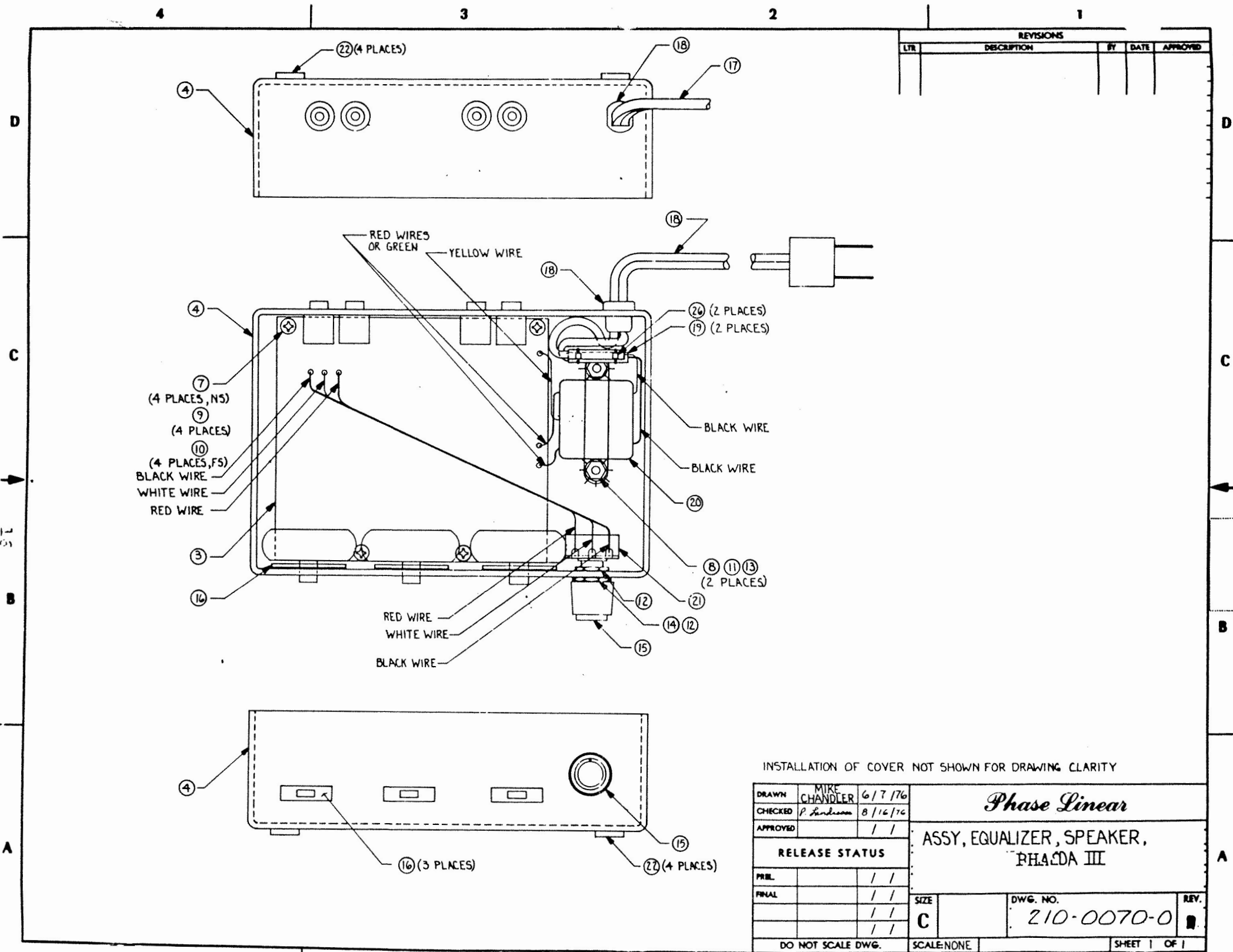

REVISIONS				
LTR	DESCRIPTION	BY	DATE	APPROVED

INSTALLATION OF COVER NOT SHOWN FOR DRAWING CLARITY

DRAWN	MIRE CHANDLER	6/7/76	<i>Phase Linear</i> ASSY, EQUALIZER, SPEAKER, PHACDA III	
CHECKED	P. Anderson	8/14/76		
APPROVED		/ /		
RELEASE STATUS			SIZE	DWG. NO.
PREL.		/ /	C	210-0070-0
FINAL		/ /		
		/ /		
DO NOT SCALE DWG.			SCALE: NONE	SHEET 1 OF 1

DIAGRAM II (-11

4 3 2 1

REVISIONS			
LTR	DESCRIPTION	BY	DATE
A	1. REVISED SHEET 1	M.D.C.	6-9-76
B	1. ZN B2 & B3 DELETED (6) CALLOUTS 2. ZN B2 (4) WAS (5) 3. ZN B4 ADDED (2) TO CALLOUT	M.D.C.	7-15-76

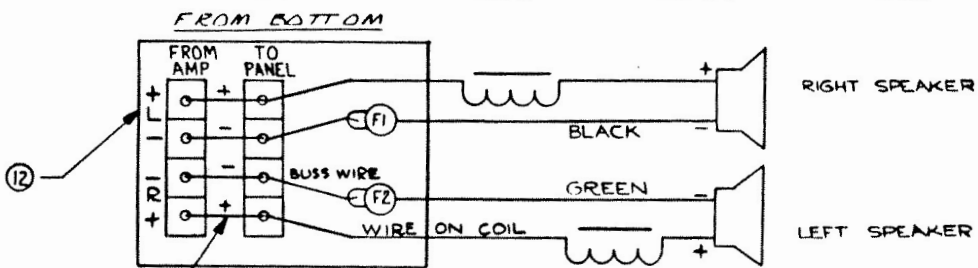

#22 AWG SOLID TINNED BUS WIRE - TYP, 6 PLACES

(21) WIRING DIAGRAM

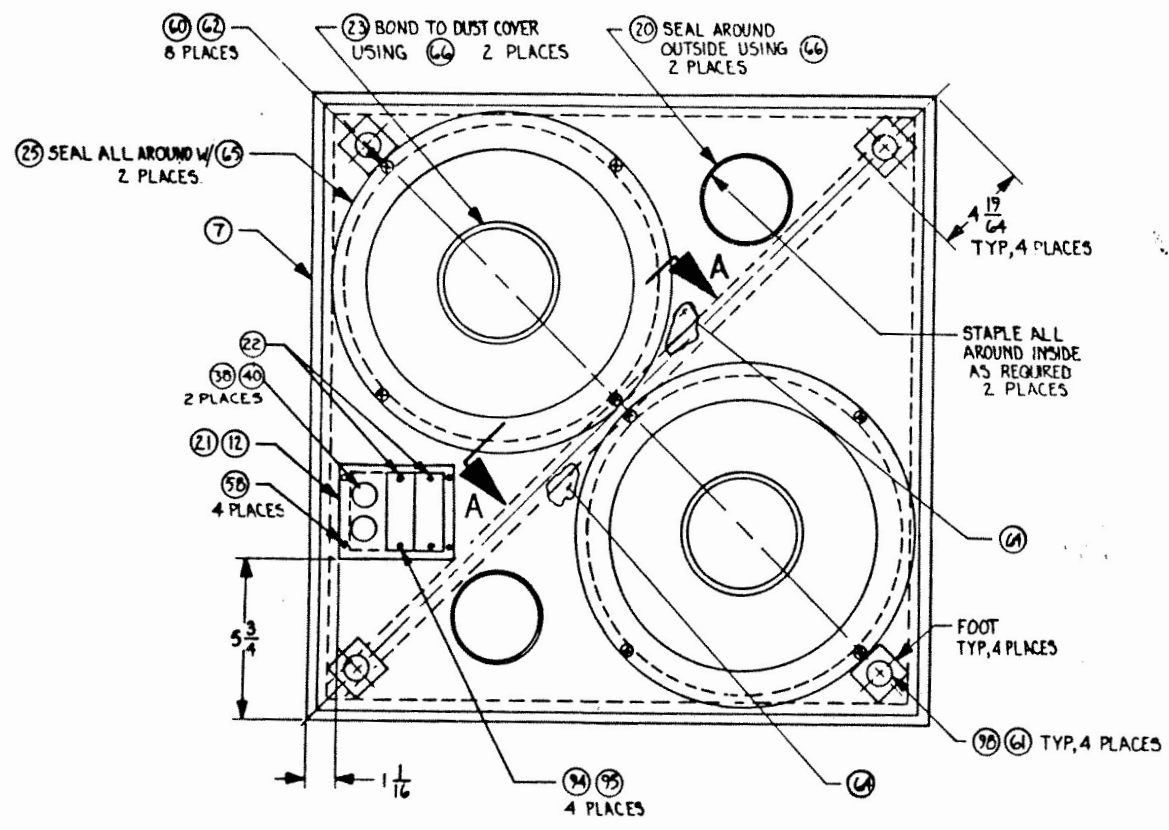

(6) BASS SPEAKER ASSY

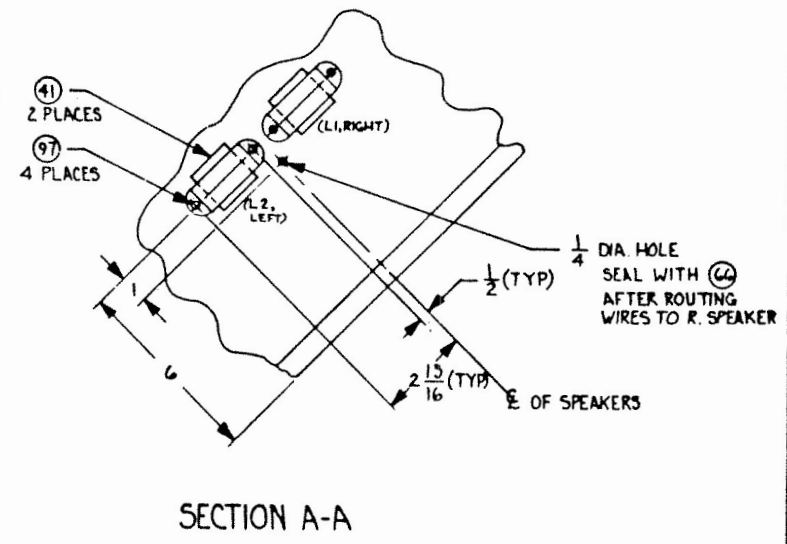

UNLESS OTHERWISE SPECIFIED DIM. AND TOL. ARE IN INCHES AND SHALL BE INTERPRETED PER (ANSI) Y14.5-1964. TOLERANCES ARE: 1 DEC ± .1 2 DEC ± .01 3 DEC ± .008 4 DEC ± .0008 ANGLES ± 9° 30'	DRAWN	MIRE CHANDLER	5/4/76	<i>Phase Linear</i>	
	CHECKED	P. Anderson	5/17/76		
	APPROVED		/ /	A	
REMOVE BURRS, BRK SHARP EDGES MACH SURFACES 1/2"	RELEASE STATUS			SIZE	DWG. NO.
MAT'L:	PRIL		/ /	C	210-0069-0
FINISH:	PRAL		/ /		REV. B
HT. TREAT:			/ /	DO NOT SCALE DWG.	SCALE: NONE
				SHEET / OF /	

4-0. MOTION CONTROL MODULE TEST AND ALIGNMENT PROCEDURE

Input signal shall be 250mV @ 2K Hz. Unless otherwise stated all dB measurements are + 1dB

For Phase III Systems with Panel Serial Numbers 1736 and Earlier:

- 4-1: With all trim controls set at "0" position drive the inputs with a 250mV 2K Hz signal and obtain a 0dB reference at the outputs.
- 4-2: Repeat step 4-1 with a 1K Hz signal and verify a signal boost of 2dB from the 0dB reference. Switch the "MID" control to "+" position and verify another signal boost of 1.5dB. Switch control from "+" position to "-" position and verify a signal drop of 2.5dB. Return control to "0" position.
- 4-3: Repeat step 4-1 with a 30 Hz signal and verify a signal boost of 8.5dB from the 0dB reference. Switch the "LOW" trim control to the "+" position and verify another signal boost of 6dB. Switch control from "+" position to "-" position and verify a signal drop of 7.5dB. Return control to "0" position.
- 4-4: Repeat step 4-1 with a 20K Hz signal and verify a signal boost of 4dB from the 0dB reference. Switch "HIGH" control to "+" position and verify another signal boost of 6db. Switch control from "+" position to "-" position and verify a signal drop of 9.5dB. Return control to "0" position.
- *) 4-5: Repeat step 4-1. With the "Spatial Imaging" control set fully counterclockwise unplug the right channel input and verify that the right channel output has dropped 50dB, + 3dB. Now turn the Spatial Imaging control fully clockwise and verify that the right channel output is now inverted and 10dB lower than the left channel, + 3dB.

(*) Signal input may have to be increased in order to obtain separation measurements.

For Phase III Systems with Panel Serial Numbers 1736 and Forward:

- 4-6: With all trim controls set at "0" position drive the inputs with 250mV 2K Hz signal and obtain a 0dB reference.
- 4-7: Repeat step 4-6 with a 200 Hz signal and verify another boost of 2dB. Switch "MID" control to "+" position and verify another signal boost of 2dB. Switch control from "+" position to "-" position and verify a signal drop of 4dB. Return control to "0" position.
- 4-8: Repeat step 4-6 with a 30 Hz signal and verify a signal boost of 3dB from the 0dB reference. Switch "LOW" control to "+" position and verify another signal boost of 2dB. Switch control from "+" position to "-" position and verify signal drop of 6db. Return control to "0" position.
- 4-9: Repeat step 4-6 with a 20K Hz signal and verify a signal boost of 3 db from the 0dB reference. Switch "HIGH" control to "+" position and verify another signal boost of 4dB. Switch control from "+" position to "-" position and verify a signal drop of 8dB. Return control to "0" position.
- (*) 4-10: Repeat step 4-6. With the "Spatial Imaging" control set fully counterclockwise unplug the right channel input and verify that the right channel output has dropped 50db, + 3dB. Now turn the Spatial Imaging control fully clockwise and verify that the right channel output is now inverted and 10dB lower than the left channel, + 3dB.

(*) Signal input may have to be increased in order to obtain separation measurements.

5-0. SPEAKER PANEL AND BASS COMMODE TEST PROCEDURE

Panel Test:

Phase III speaker panels are tested at the factory in a special acoustic environment. The test procedure involves the use of a sweep signal oscillator, pink noise generator, sound pressure level meter, and realtime analyzer.

Since most repair facilities are not equipped with such speaker testing equipment the easiest method of testing the speakers is to simply listen to them since most speaker failures are audibly straightforward. A defective driver will normally manifest itself by either giving no audible sound whatsoever, or giving a definite audible distortion or breaking up of the signal.

To give the panels a listening test drive them with a low noise signal source (e.g., sine wave sweep oscillator, or quiet record or tape with fairly dynamic material) at various sound pressure levels and listen to each driver in the panel. In the case of the tweeters it may be necessary to make a "listening tube" by rolling up a piece of paper and listen to each tweeter through this tube as sometimes a tweeter may be hard to hear by merely placing your ear close to it. Verify that there is 1) sound coming from each driver, and 2) that there is no audible break-up or distortion.

If an entire set of drivers goes silent, such as all of the tweeters, both midrange drivers, etc., the problem probably lies with the crossover assembly and it may be necessary to give each component on the crossover board which is in circuit with the set of drivers a continuity check (refer to the appropriate crossover schematic in Section III).

Bass Commode Test:

The bass commode is tested at the factory using a sweep signal oscillator (with amplification) and is driven in a sweep mode from around 100Hz down to 5Hz. This allows not only an audible check of each driver's performance, but offers an audible check for air leaks or vibrations in the cabinet.

To test the bass commode the same sort of test may be utilized, or if a signal oscillator isn't available it may be driven with a low noise record or tape which contains suitable bass material. Verify that both drivers give an audible signal and that the material is free of distortion, break-up, rattles or air leaks.

<u>Description</u>	<u>Part No.</u>	<u>Description</u>	<u>Part No.</u>
12" Bass Driver.....	129-0039-0	Cap, 130/50V NP.....	127-0087-0
8" Midbass Driver.....	129-0040-0	Cap, 20/50V NP.....	127-0086-0
4" Midrange Driver.....	129-0041-0	Cap, 6.8/50V NP.....	127-0085-0
2" Cone Tweeter.....	129-0042-0	Cap, 3.3/100V NP	127-0115-0
1" Soft-Dome Tweeter.....	129-0082-0	Res., 75 Ohm 5W.....	128-0375-0
Crossover Assy:		Res., 15 Ohm 5W.....	128-0363-0
Ser#1736 & Earlier.....	210-0072-0	Res., 7.5 Ohm 10W.....	128-0376-0
Ser#1736 & Forward.....	210-0077-0	Res., 8.2 Ohm 2W.....	128-0361-0
ABS Plastic Tweeter Bracket: 3-pc.		Res., 6.8 Ohm 2W.....	128-0373-0
Left.....	141-0144-0	Res., 3.3 Ohm 2W.....	128-0360-0
Right.....	141-0145-0	Res., 2.7 Ohm 2W.....	128-0374-0
Ring.....	143-0014-0	Binding Post (red)....	121-0007-0
Tweeter Cone Deflector...	142-0019-0	Binding Post (black)..	121-0008-0
8" Mounting Gasket.....	121-0084-0	Fuseholder (AGC).....	121-0010-0
Speaker Panel (raw).....	130-0004-0	Fuse, AGC-4.....	121-0104-0
Walnut Panel Side Strip..	130-0009-0	Motion Control Module.	210-0070-0
Walnut Panel Foot.....	130-0007-0	IC, RC4136.....	126-0027-0
Metal Panel Foot.....	141-0047-0	IC, RC4739.....	126-0029-0
Grille Frame.....	130-0006-0	Relay, 2V reed.....	129-0044-0
Grille Frame Assy.....	210-0086-0	Jack, RCA, PCB-mount..	121-0022-0
Bass Cabinet (raw).....	130-0005-0		
Bass Inductor.....	125-0014-0		
Bass Terminal Board Assy.	210-0074-0		
Push-connect Term. Strip.	121-0064-0		
Bass Cabinet Foot.....	130-0010-0		

NOTE: Whenever ordering parts BE SURE TO INCLUDE THE PANEL SERIAL NUMBER OF THE SPEAKER SYSTEM.

SERVICE BULLETIN

SUBJECT: Phase III Motion Control Module

We have discovered that due to the positive feedback used in one of the frequency contouring stages the Motion Control Module will oscillate (10v AC @ about 200Hz) if the inputs are opened. This can happen when switching the tone controls in and out on a preamp which has a non-shortening tone switch (such as the Phase 2000). To arrest this oscillation the inputs should be referenced to ground through a 47K-ohm resistor. The resistor should be soldered on the foil side of the PC board from each input hot (+) to the ground plane provided for the shorting input jacks.

Thus far the oscillation has proven to be a rare complaint but can be a potential hazard to unfused speakers. If you have any further questions feel free to contact the factory service department at the following address:

PHASE LINEAR
20121-48th AVE. WEST
LYNNWOOD, WA 98036
(206) 774-8848

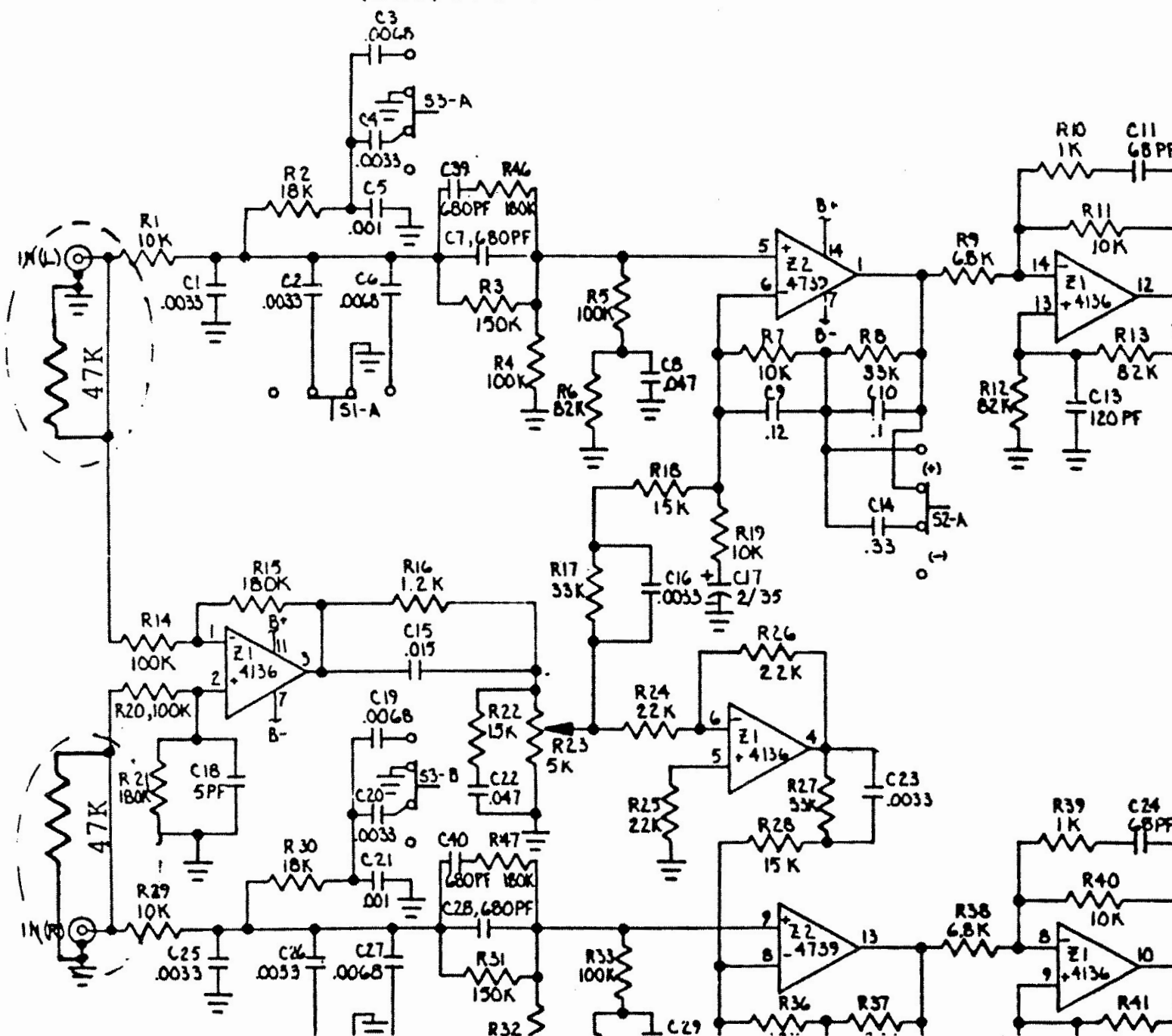

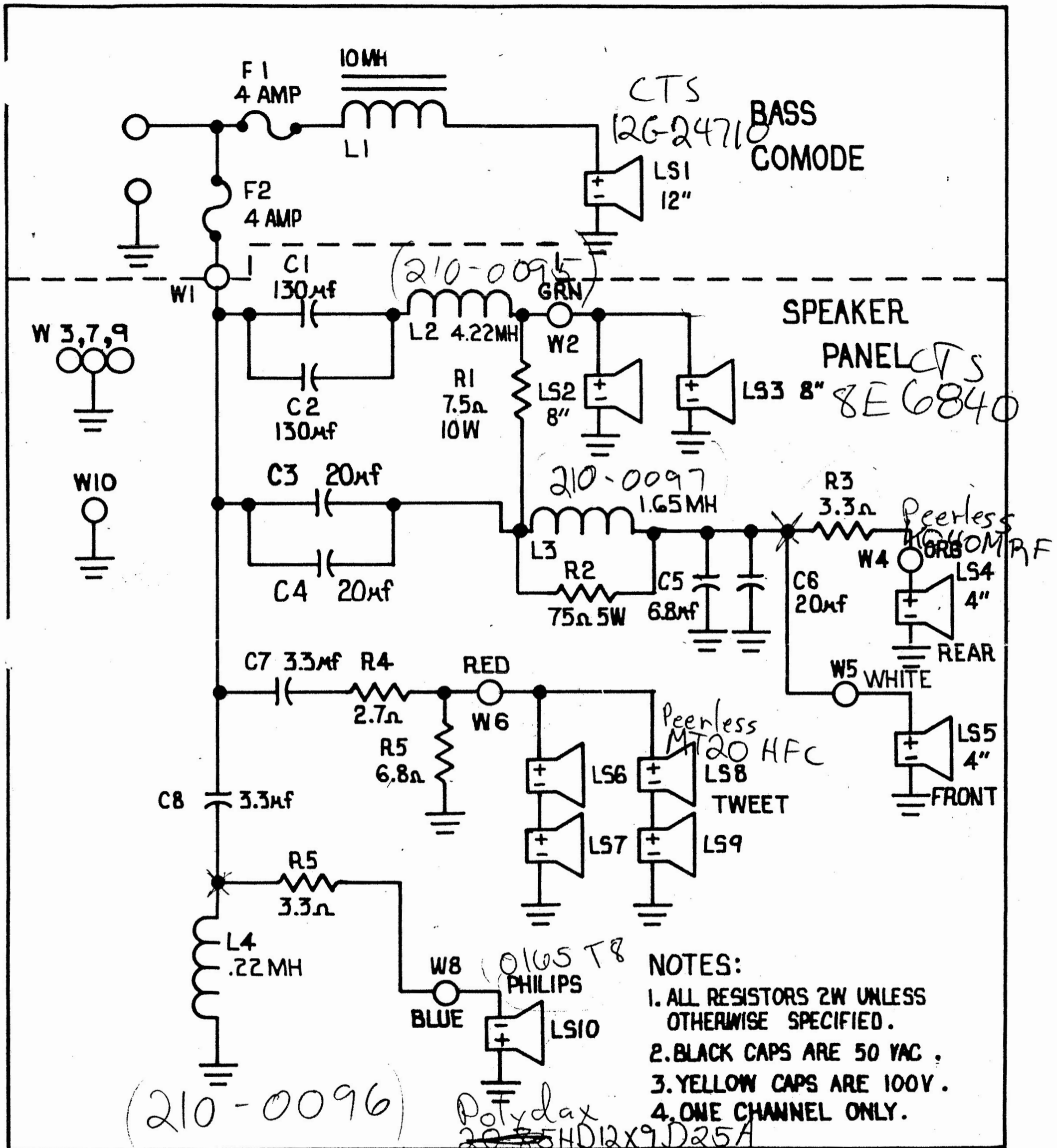

PHASE LINEAR

SCHMATIC
PHASE III SPEAKER

DRAWN	R. CLARK	11-22-77
CHECKED		
APPROVED		

Serial Number 1736 Forward

REV