

TUNER

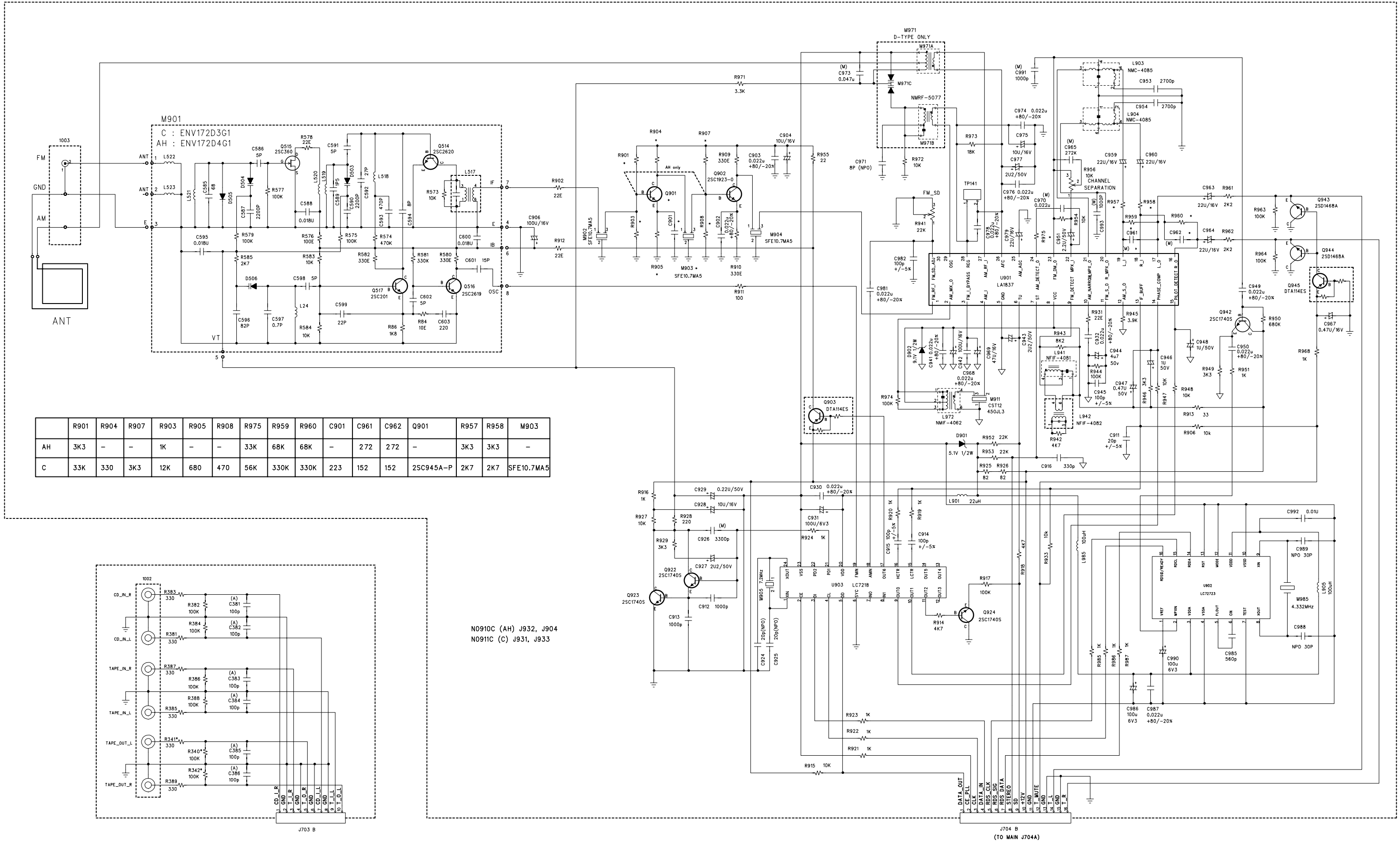

NOTE: 1. RESISTORS ARE CARBON FILM 5% 1/8W UNLESS OTHERWISE SPECIFIED.
 2. CERAMIC CAPACITORS ARE 50V 10%. UNLESS OTHERWISE SPECIFIED.

S-VIDEO

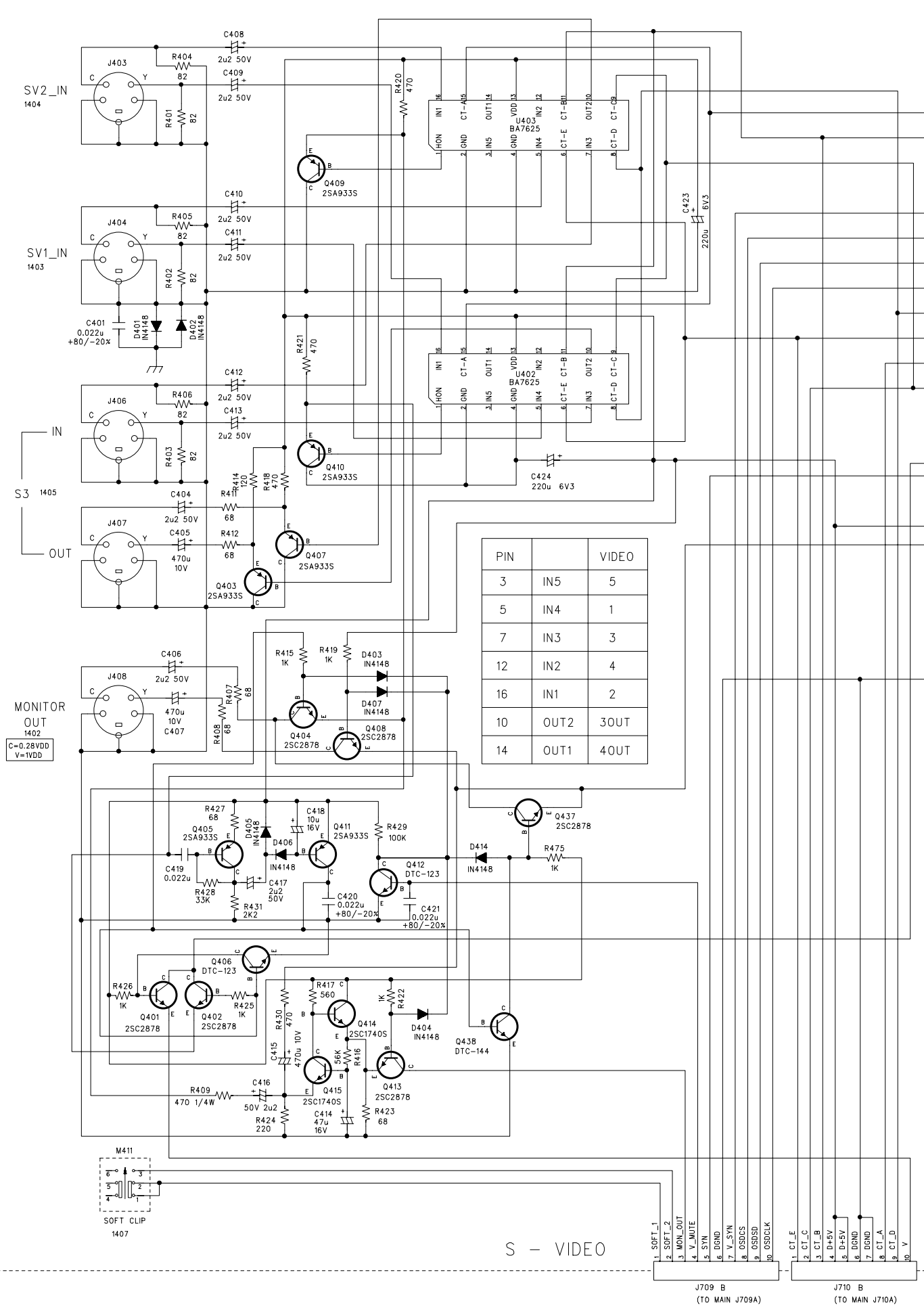

PIN	VIDEO
3	IN5
5	IN4
7	IN3
12	IN2
16	IN1
10	OUT2
14	OUT1
	3OUT
	4OUT

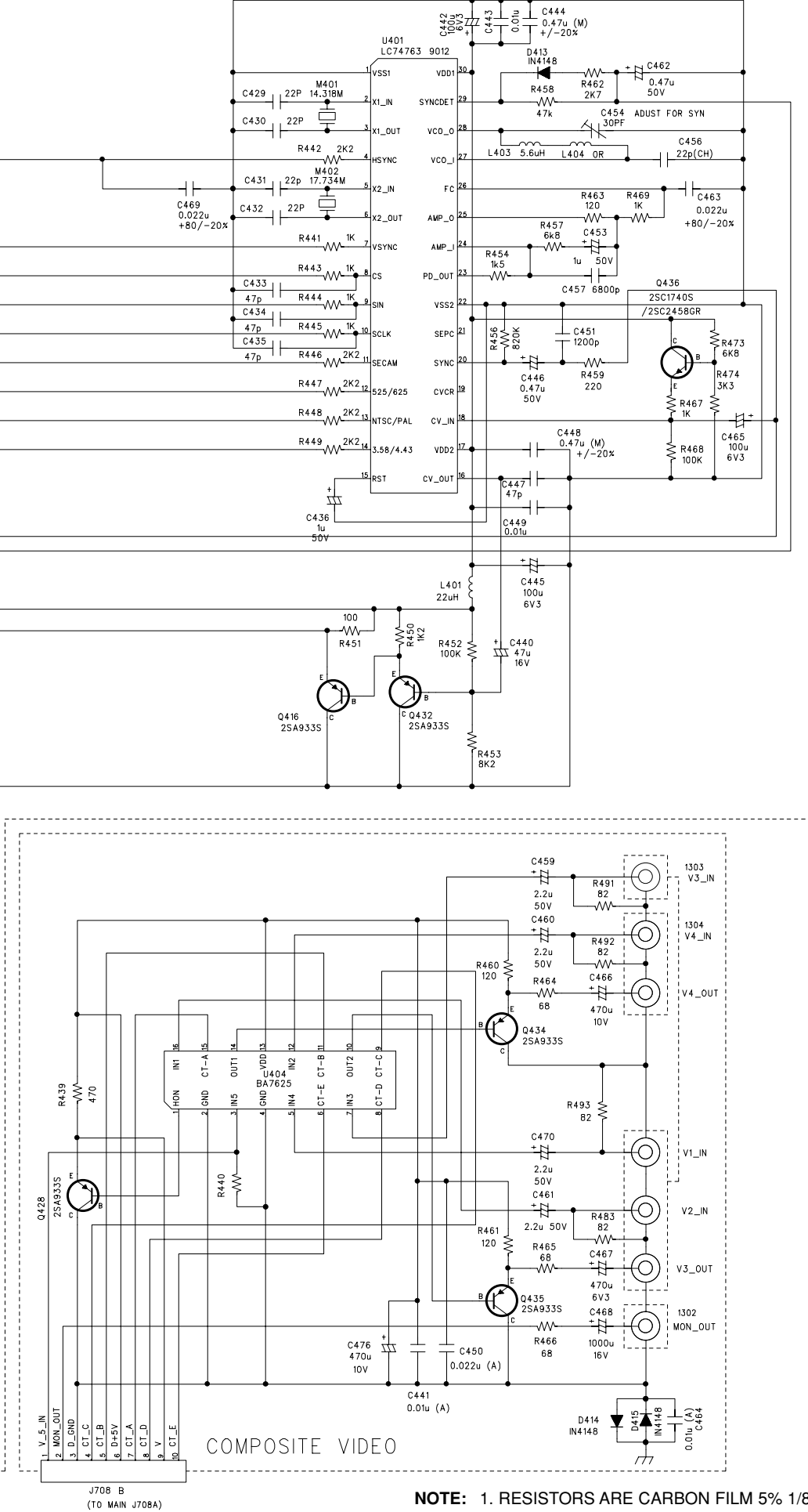

NOTE: 1. RESISTORS ARE CARBON FILM 5% 1/8W UNLESS OTHERWISE SPECIFIED.
2. CERAMIC CAPACITORS ARE 50V 10%. UNLESS OTHERWISE SPECIFIED.

AUDIO

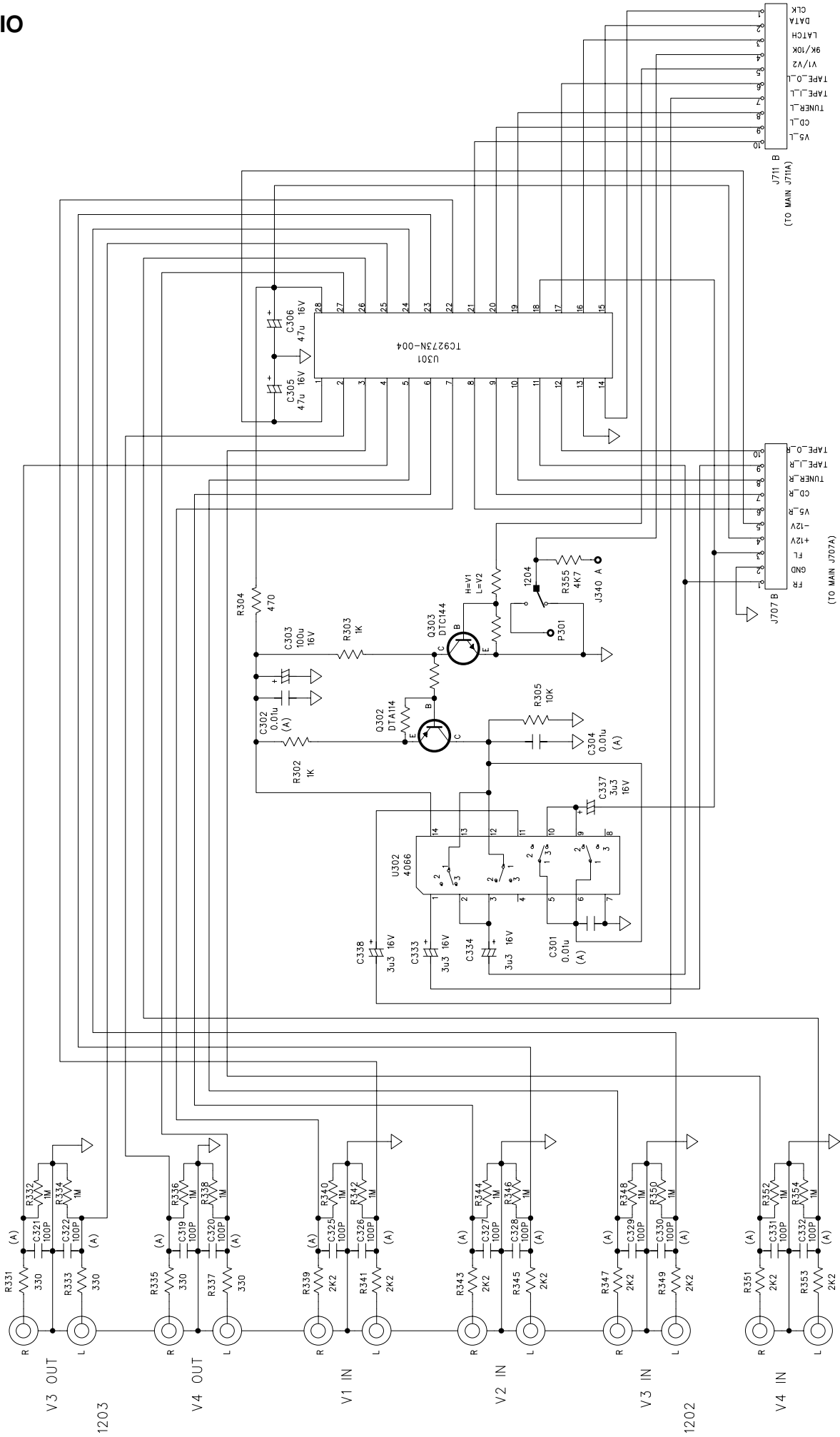

NOTE: 1. RESISTORS ARE CARBON FILM 5% 1/8W UNLESS OTHERWISE SPECIFIED.
 2. CERAMIC CAPACITORS ARE 50V 10% UNLESS OTHERWISE SPECIFIED.

POWER SUPPLY UNIT

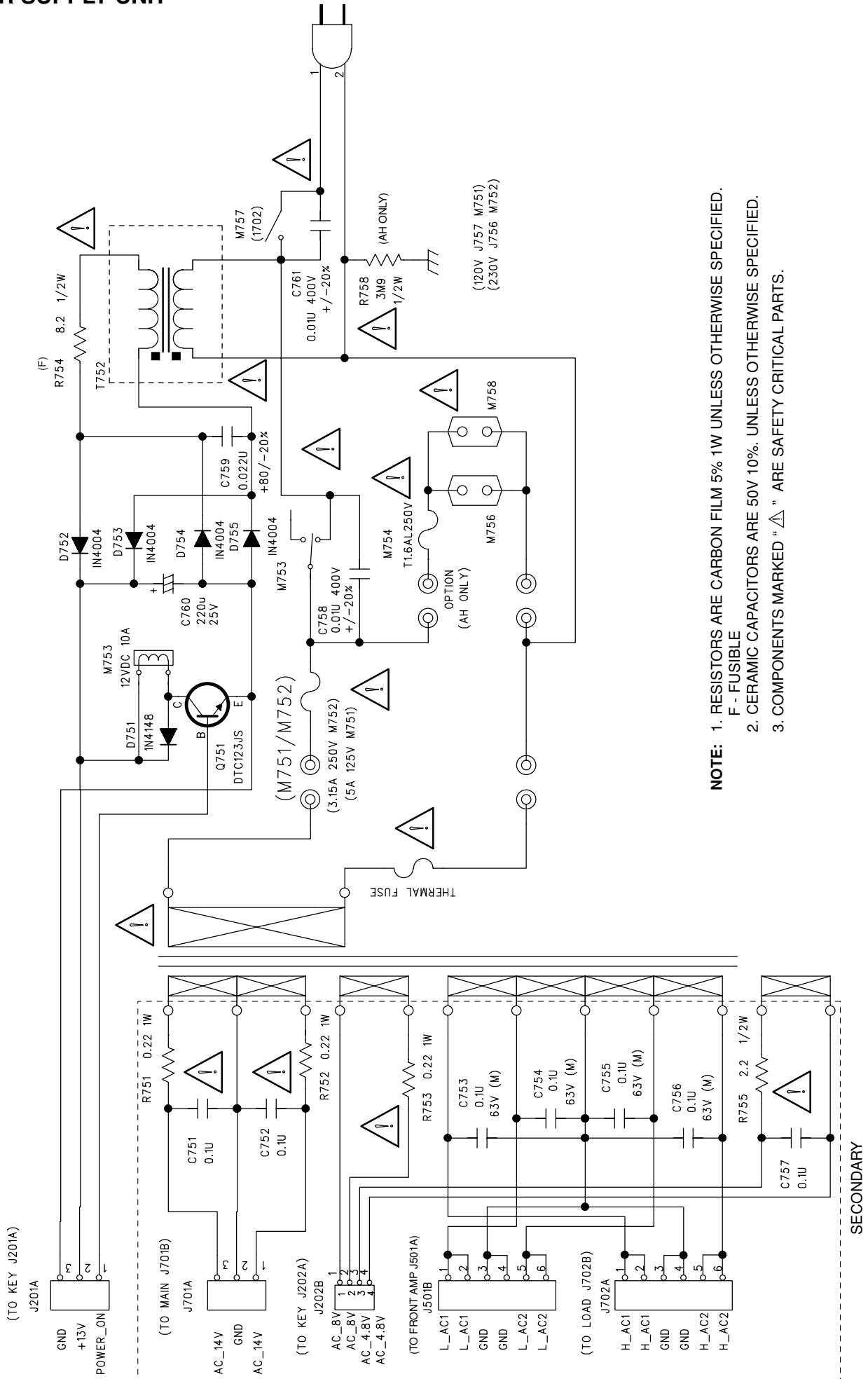

NOTE: 1. RESISTORS ARE CARBON FILM 5% 1W UNLESS OTHERWISE SPECIFIED.
 F - FUSIBLE
 2. CERAMIC CAPACITORS ARE 50V 10%. UNLESS OTHERWISE SPECIFIED.
 3. COMPONENTS MARKED "△" ARE SAFETY CRITICAL PARTS.

IC BLOCK DIAGRAM

AC3 BOARD
U101: 74HC153

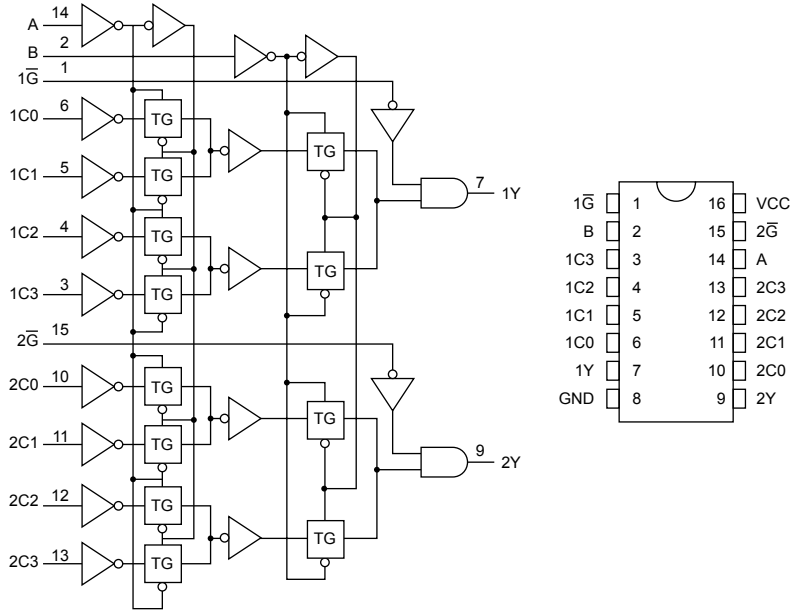

AC3 BOARD
U102: 74HC157

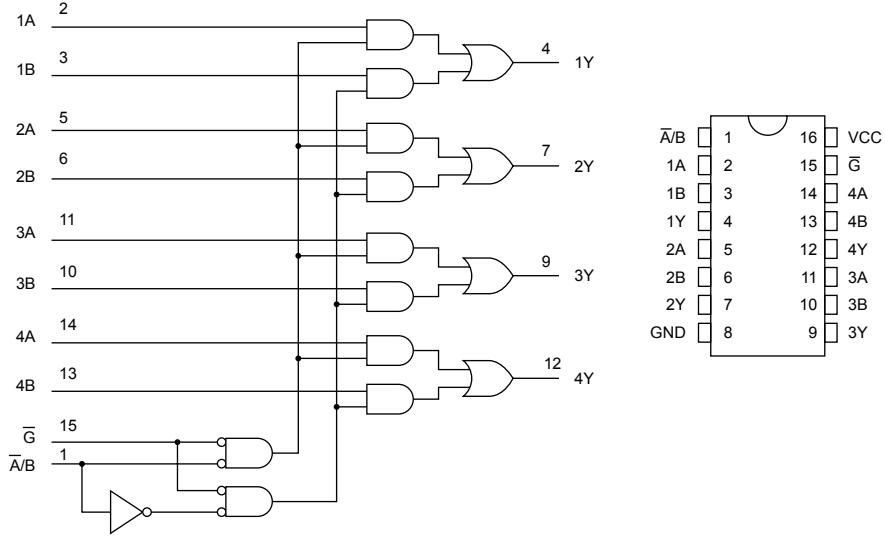

AC3 BOARD
U103: CS5331A

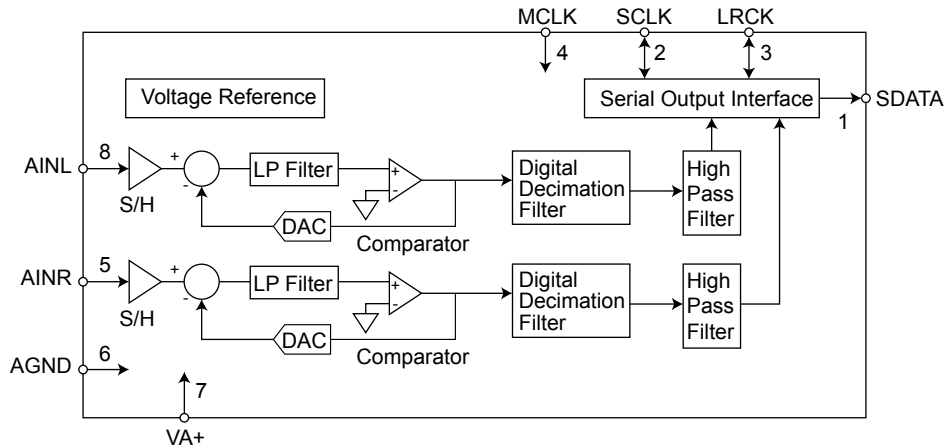

AC3 BOARD

U104, U109, U116,
U131, U134: NJM5532

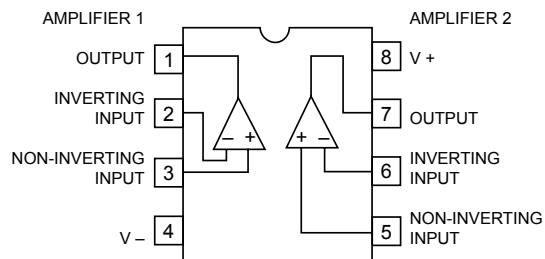

AC3 BOARD

U108: AT27C020-70

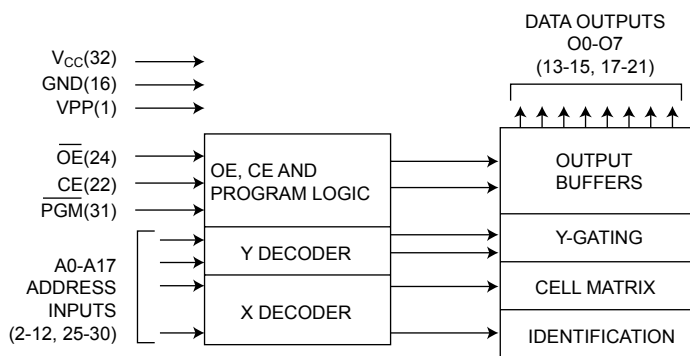

AC3 BOARD

U105: CS4926

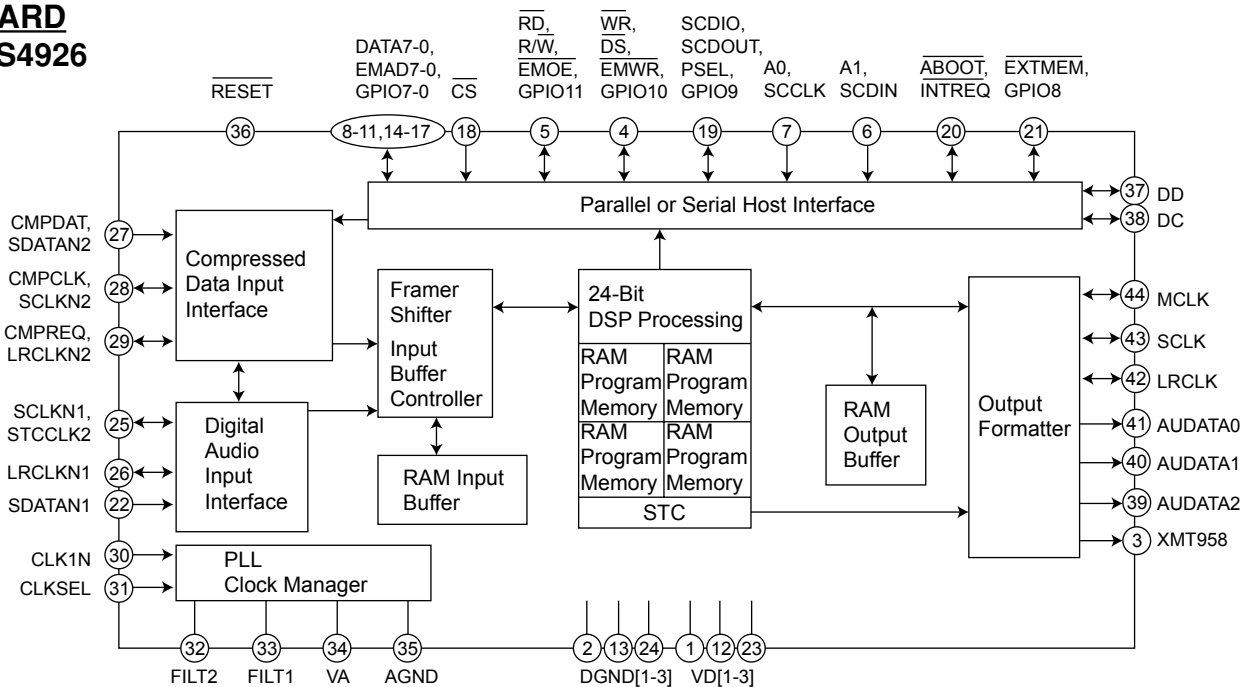

AC3 BOARD

U106, U107: 74HC574

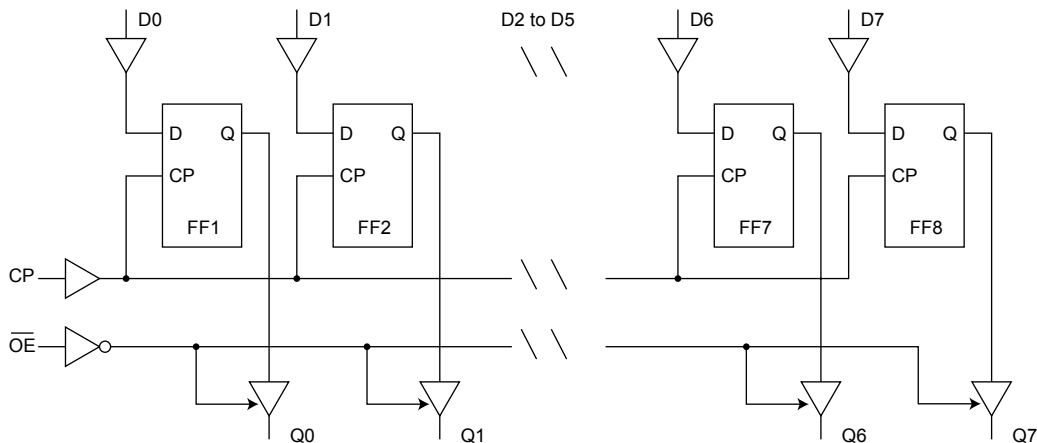

AC3 BOARD
U110: CS8414

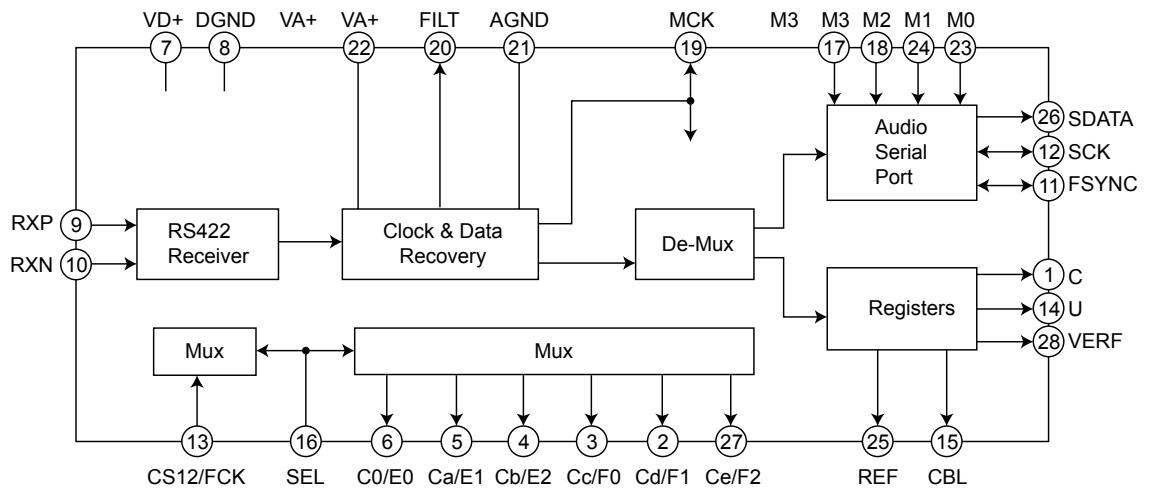

AC3 BOARD
U111-U113: CS4340

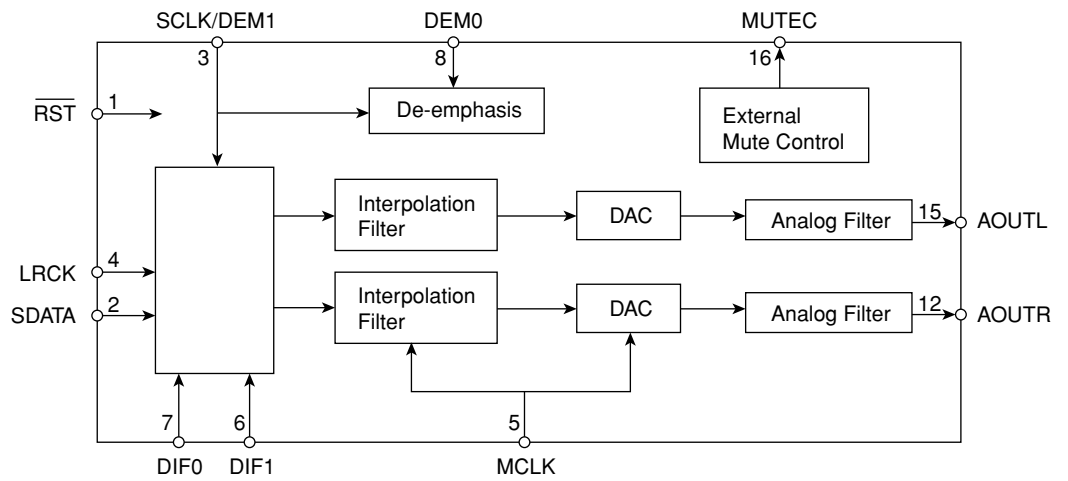

AC3 BOARD
U115,U117, U120: 74HC74

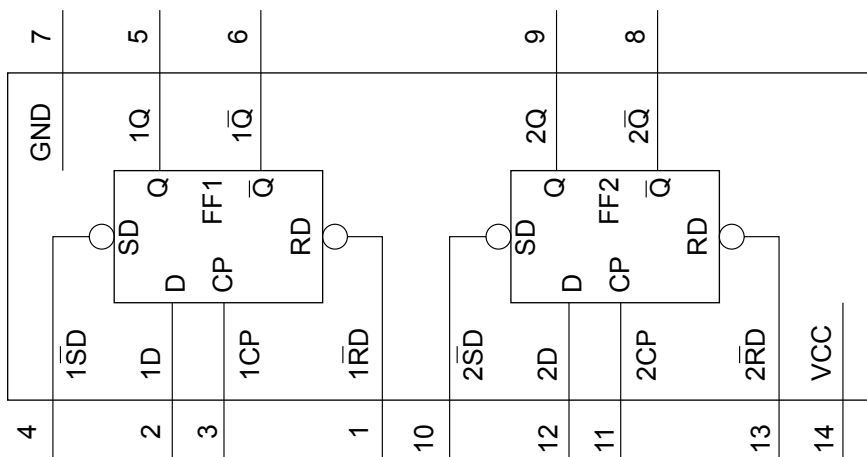

AC3 BOARD

U114: 74HCU04

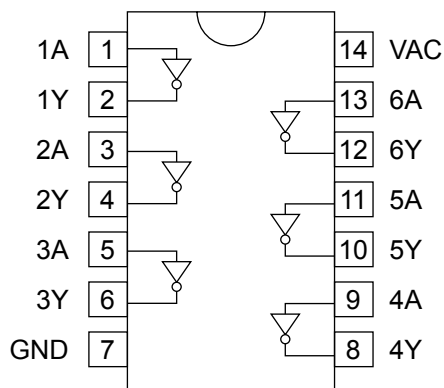

AC3 BOARD

U118-U119: 74HC00

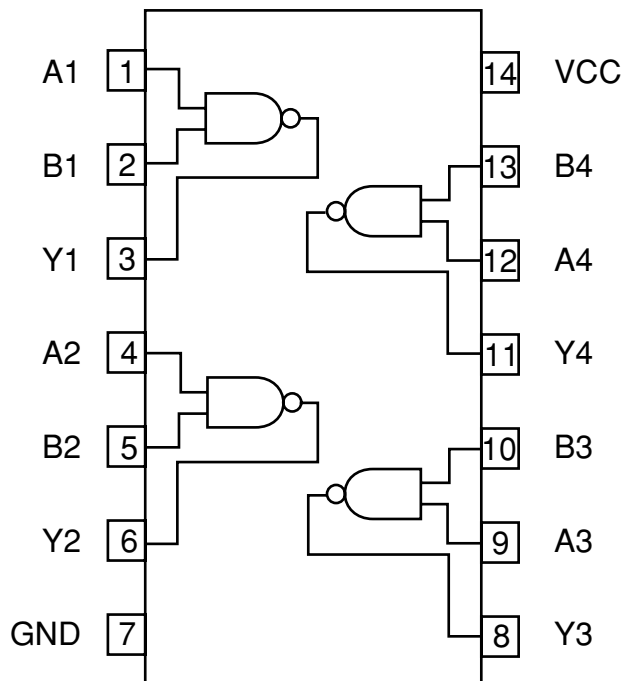

AUDIO BOARD

U301: TC9273N-004

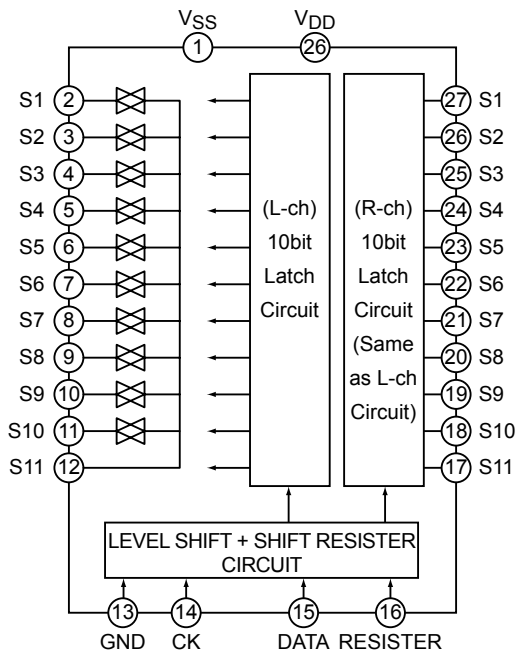

AUDIO BOARD

U302: 4066

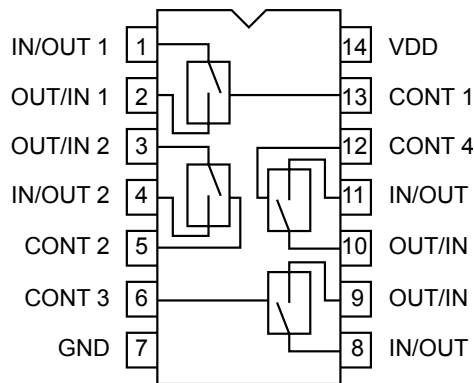

DIGITAL BOARD

U761: 74HCT00

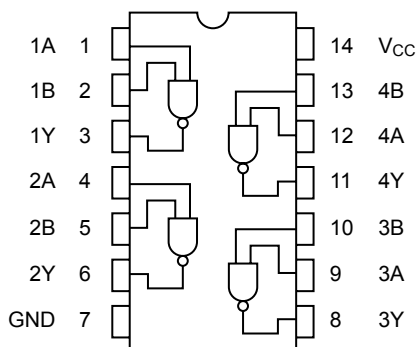

LOAD BOARD

U701: NJM4558D

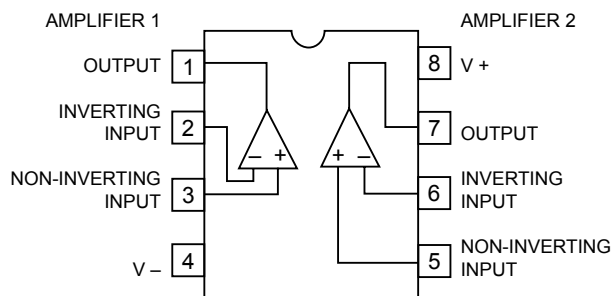

MULTI-CHANNEL BOARD

U601: M62447SP

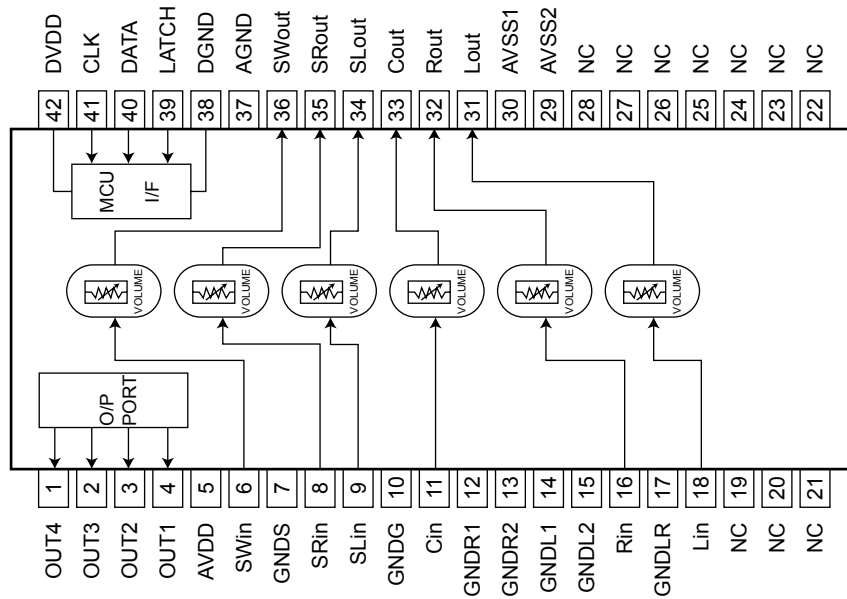

MULTI-CHANNEL BOARD

U602: TC9164AN

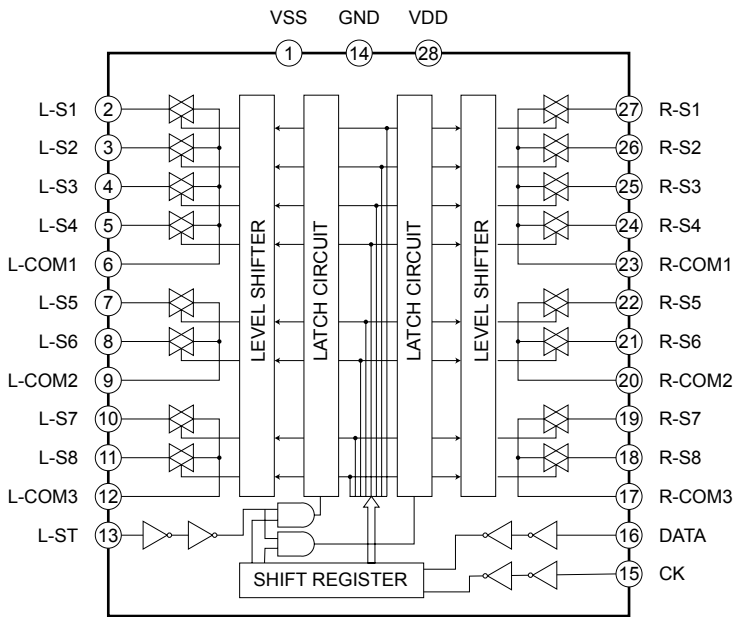

MULTI-CHANNEL BOARD

U605-U611: NJM5532

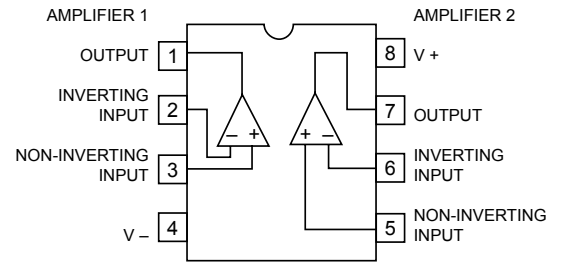

MAIN BOARD

U723: NJM78M56FA

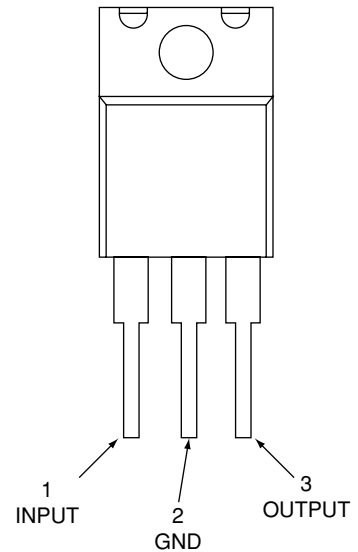

S-VIDEO & VIDEO BOARD

U402-U404: BA7625

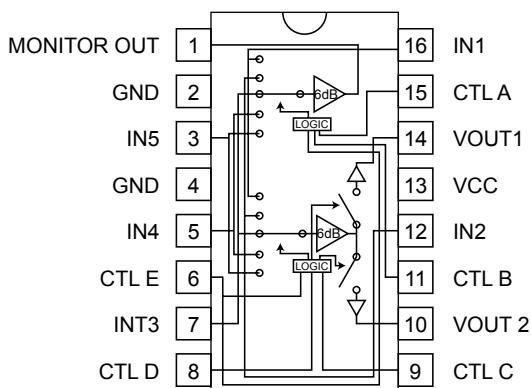

S-VIDEO BOARD

U401: LC74763-9012

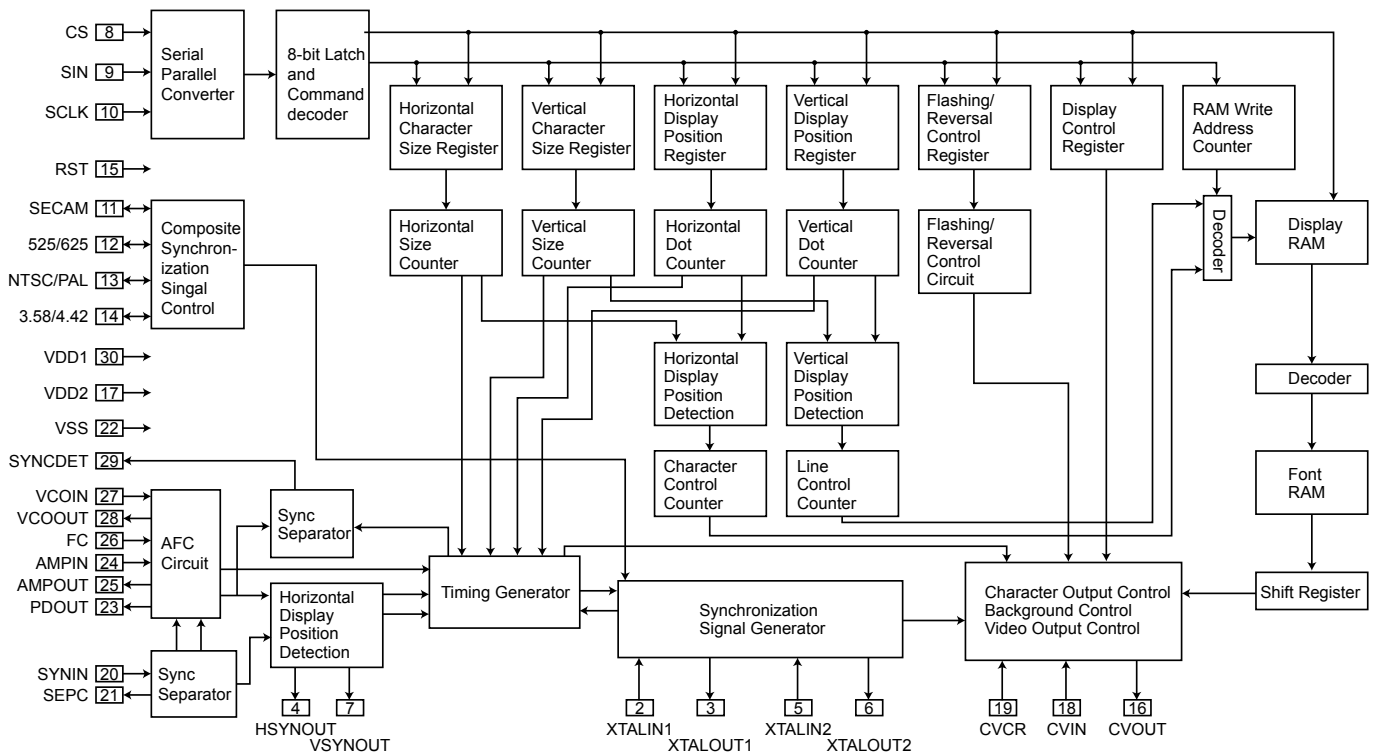

KEY BOARD

U201: LC87F65C8A

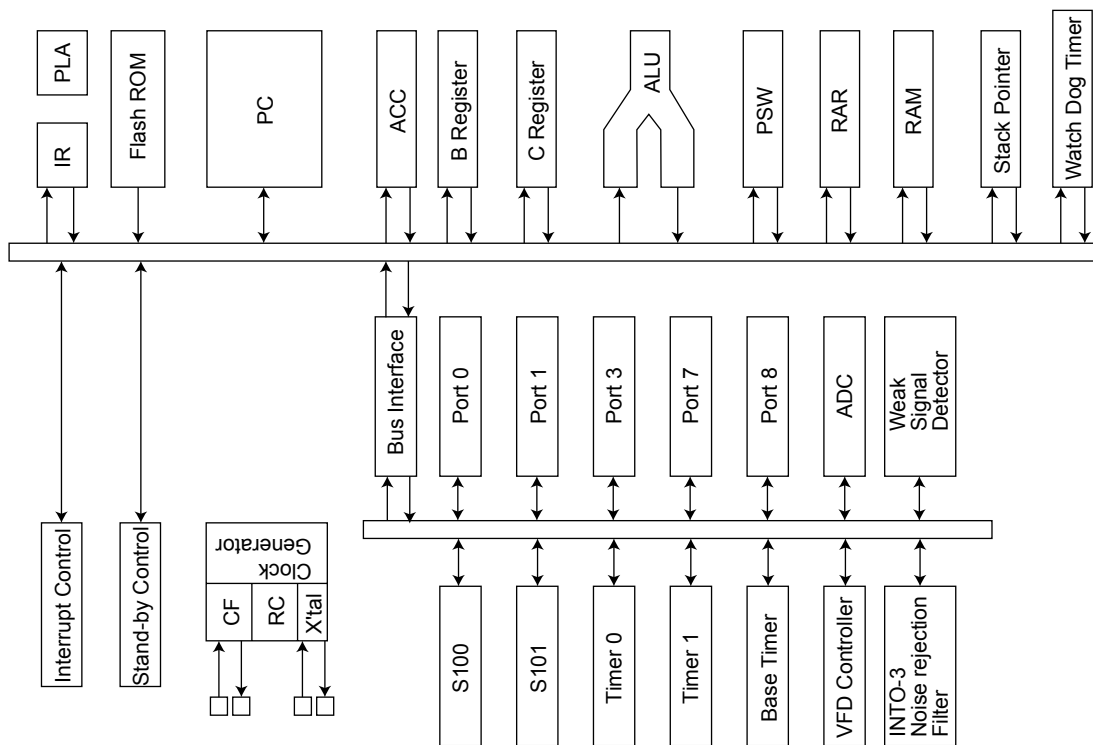

KEY BOARD
U202: EEPROM 24C02

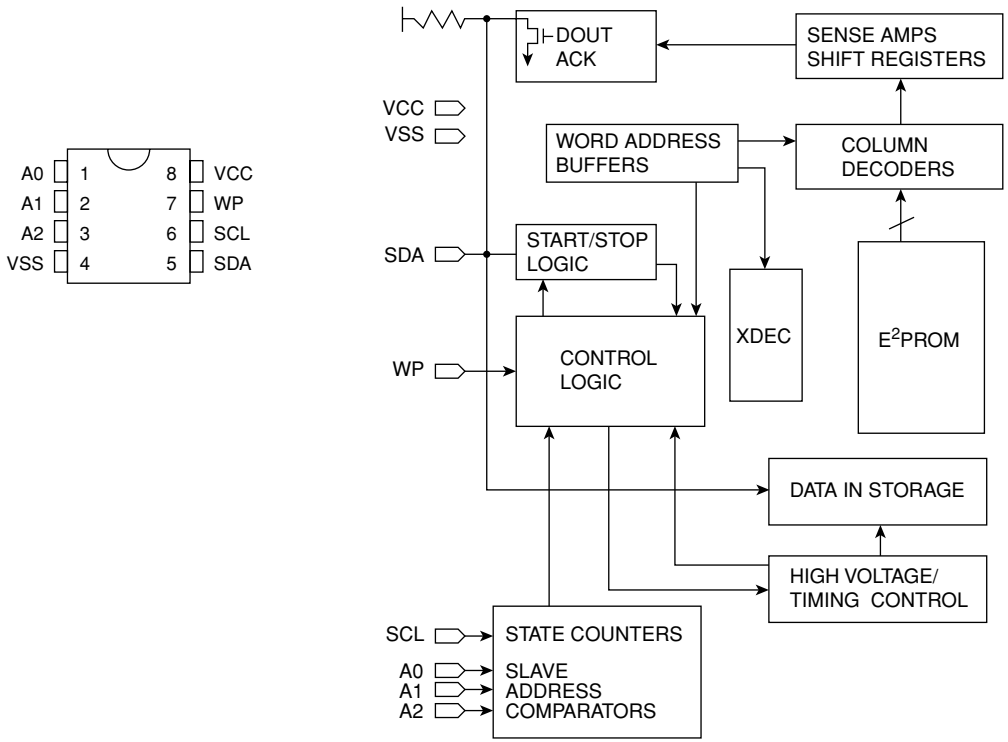

TUNER BOARD
U901: LA1837

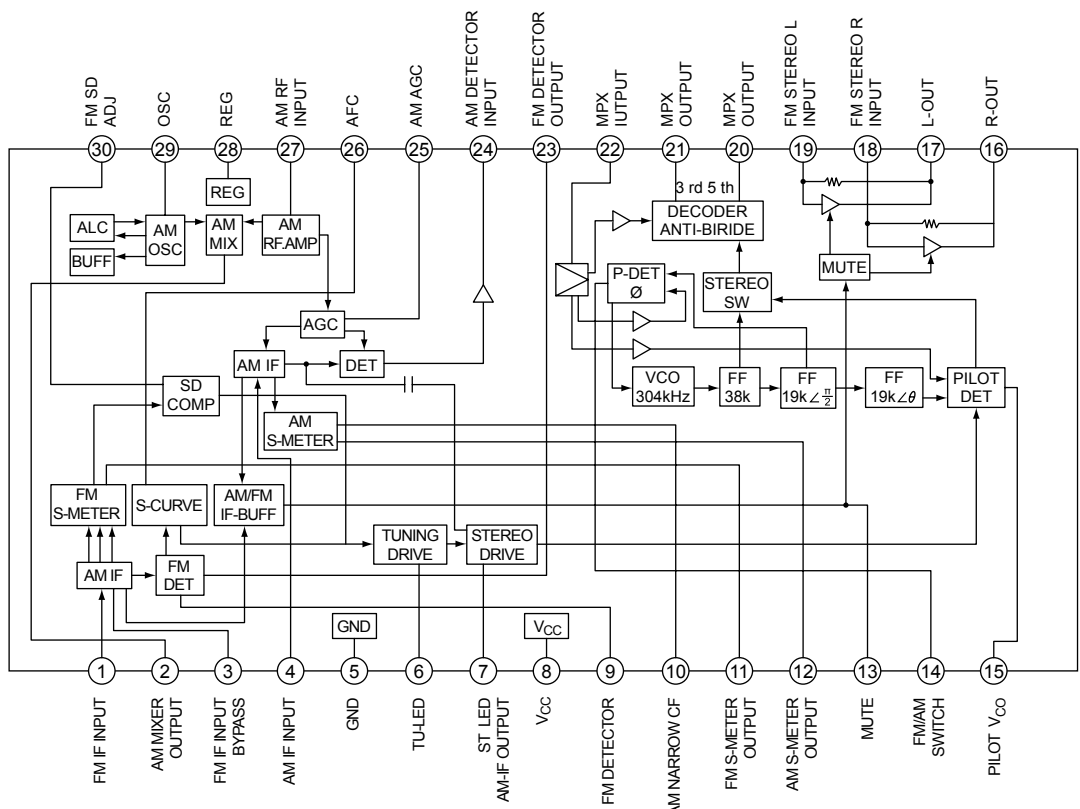

TUNER BOARD
U902: LC72723M

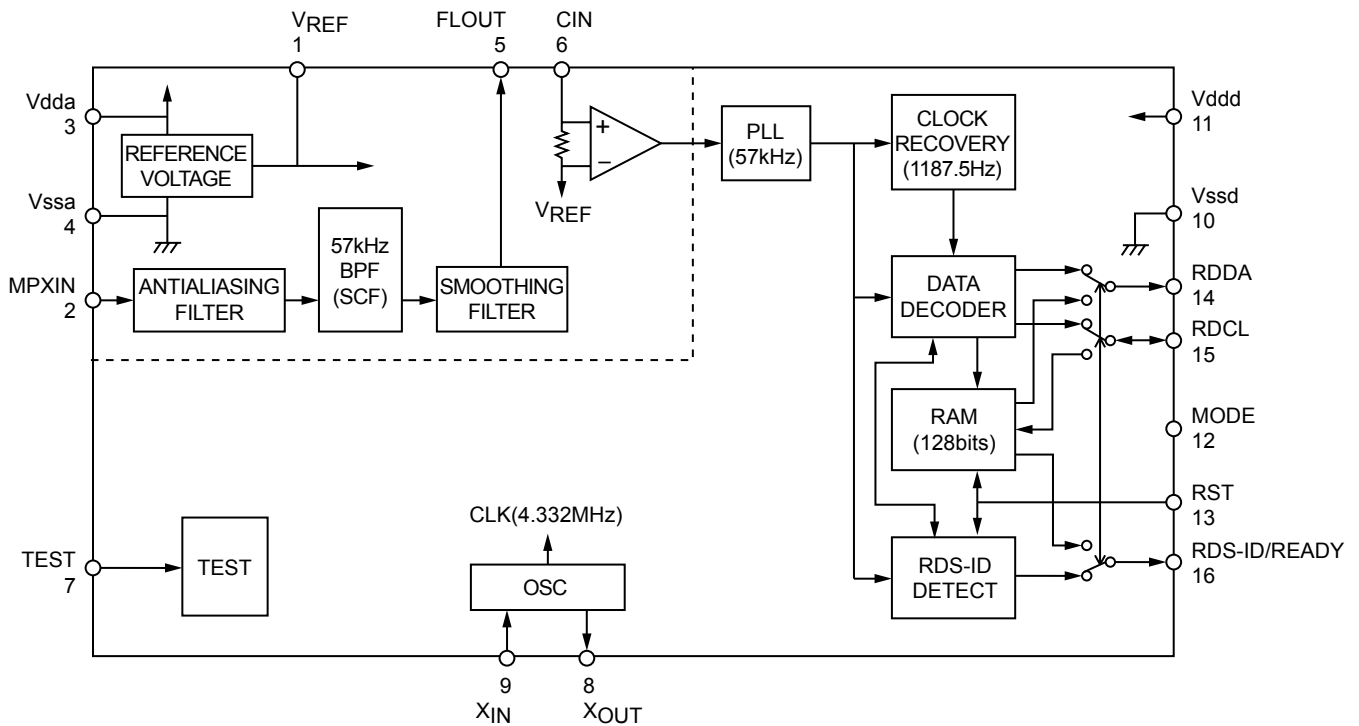

TUNER BOARD
U903: LC7218

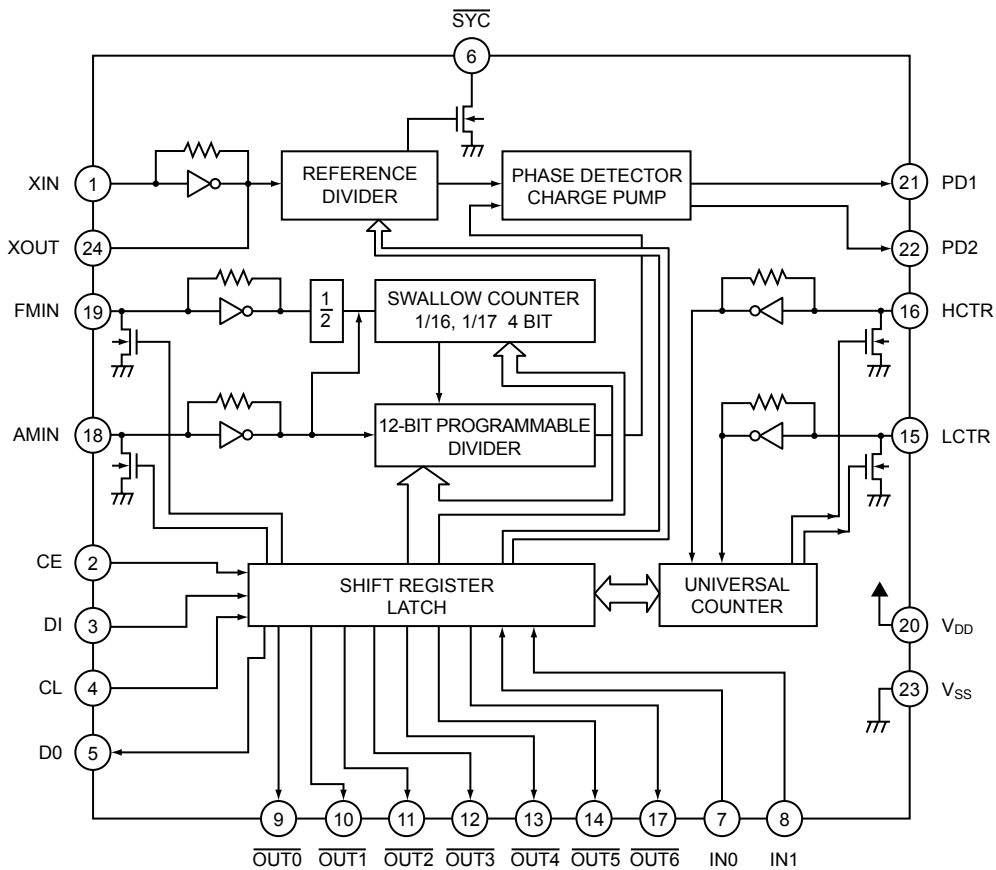

ELECTRICAL PARTS LIST

<u>Reference No.</u>	<u>Part No.</u>	<u>Description</u>
<u>AC3 BOARD ASSEMBLY</u> <u>PC BOARD</u> 2701	PCB-N0910C-AC3	PCB ASSY AC3 N091XC
<u>CAPACITORS</u>		
C101	150F-104K-J-BD	CC 50V 0.1μF 10% 0805 1.2x2.0
C102	150E-104M-J-BD	CC 25V 0.1μF20% 0805 1.2x2.0
C103	150F-104K-J-BD	CC 50V 0.1μF 10% 0805 1.2x2.0
C104	157C-108M-5-S5	CE 10V 1000μF 20% RL 10x16
C105	150F-103K-J-BD	CC 50V 0.01μF 10% 0805 1.2x2.0
C106	150F-104K-J-BD	CC 50V 0.1μF 10% 0805 1.2x2.0
C107	157D-228M-5-W9	CE 16V 2200μF 20% RL 12x20
C108	150F-104K-J-BD	CC 50V 0.1μF 10% 0805 1.2x2.0
C114-C115	157D-226M-5-GM	CE 16V 22μF 20% RL 4x7
C117, C119	157D-475M-5-EI	CE 16V 4.7μF 20% RL 3x5
C120-C121	157D-226M-5-GM	CE 16V 22μF 20% RL 4x7
C122-C123	150F-562J-J-BD	CC 50V 5600pF 5% 0805 1.2x2.0
C125	150E-104M-J-BD	CC 25V 0.1μF20% 0805 1.2x2.0
C126	157D-227M-5-KW	CE 16V 220μF 20% RL 6x12
C127	150E-104M-J-BD	CC 25V 0.1μF20% 0805 1.2x2.0
C128	157D-106M-5-GM	CE 16V 10μF 20% RL 4x7
C129	150E-104M-J-BD	CC 25V 0.1μF20% 0805 1.2x2.0
C130	157E-105M-5-EI	CE 25V 1μF 20% RL 3x5
C132, C134	157D-475M-5-EI	CE 16V 4.7μF 20% RL 3x5
C135-C136	150F-562J-J-BD	CC 50V 5600pF 5% 0805 1.2x2.0
C138	150E-104M-J-BD	CC 25V 0.1μF20% 0805 1.2x2.0
C139	157D-227M-5-KW	CE 16V 220μF 20% RL 6x12
C140	150E-104M-J-BD	CC 25V 0.1μF20% 0805 1.2x2.0
C141	157D-106M-5-GM	CE 16V 10μF 20% RL 4x7
C142	150E-104M-J-BD	CC 25V 0.1μF20% 0805 1.2x2.0
C143	157E-105M-5-EI	CE 25V 1μF 20% RL 3x5
C145, C147	157D-475M-5-EI	CE 16V 4.7μF 20% RL 3x5
C148	150F-562J-J-BD	CC 50V 5600pF 5% 0805 1.2x2.0
C149	150F-103K-J-BD	CC 50V 0.01μF 10% 0805 1.2x2.0
C150-C151	150F-104K-J-BD	CC 50V 0.1μF 10% 0805 1.2x2.0
C152	150F-103K-J-BD	CC 50V 0.01μF 10% 0805 1.2x2.0
C153	157D-106M-5-GM	CE 16V 10μF 20% RL 4x7
C154	150F-104K-J-BD	CC 50V 0.1μF 10% 0805 1.2x2.0
C156	150F-683K-J-BD	CC 50V 0.068μF 10% 0805 1.5x2.5
C157	150F-104K-J-BD	CC 50V 0.1μF 10% 0805 1.2x2.0
C158	157D-476M-5-IU	CE 16V 47μF 20% RL 5x11
C159	150F-104K-J-BD	CC 50V 0.1μF 10% 0805 1.2x2.0
C161-C162	15FD-105Z-J-BD	CC 16V 1μF +80-20% 0805
C163-C164	150F-103K-J-BD	CC 50V 0.01μF 10% 0805 1.2x2.0
C165	157D-225M-5-GM	CE 16V 2.2μF 20% RL 4x7
C166-C167	150F-104K-J-BD	CC 50V 0.1μF 10% 0805 1.2x2.0
C168	157D-106M-5-GM	CE 16V 10μF 20% RL 4x7
C169	150F-104K-J-BD	CC 50V 0.1μF 10% 0805 1.2x2.0
C171	15FF-224Z-J-BD	CC 50V 0.22μF +80/-20% 0805
C172	153F-225J-5-TOM	CM 50V 2.2μF RL 10x8 METALLIZED
C173	157C-107M-5-IU	CE 10V 100μF 20% RL 5x11
C174	157D-106M-5-GM	CE 16V 10μF 20% RL 4x7
C175	150F-104K-J-BD	CC 50V 0.1μF 10% 0805 1.2x2.0

Reference No.	Part No.	Description
C176	157C-107M-5-IU	CE 10V 100µF 20% RL 5x11
C179-C180, C183-C184	150F-104K-J-BD	CC 50V 0.1µF 10% 0805 1.2x2.0
C193-C194, C198	150F-104K-J-BD	CC 50V 0.1µF 10% 0805 1.2x2.0
C199	157D-106M-5-GM	CE 16V 10µF 20% RL 4x7
C1101	157D-475M-5-EI	CE 16V 4.7µF 20% RL 3x5
C1102	15FF-224Z-J-BD	CC 50V 0.22µF +80/-20% 0805
C1104	157D-475M-5-EI	CE 16V 4.7µF 20% RL 3x5
C1105	15FF-224Z-J-BD	CC 50V 0.22µF +80/-20% 0805
C1106-C1107	157D-226M-5-GM	CE 16V 22µF 20% RL 4x7
C1112-C1114	150F-104K-J-BD	CC 50V 0.1µF 10% 0805 1.2x2.0
C1115	157D-106M-5-GM	CE 16V 10µF 20% RL 4x7
C1116	157E-105M-5-EI	CE 25V 1µF 20% RL 3x5
C1117	157D-475M-5-EI	CE 16V 4.7µF 20% RL 3x5
C1118	157D-227M-5-KW	CE 16V 220µF 20% RL 6x12
C1119-C1121	157D-475M-5-EI	CE 16V 4.7µF 20% RL 3x5
C1122-C1123, C1131-C1134	150F-104K-J-BD	CC 50V 0.1µF 10% 0805 1.2x2.0
C1135	150F-100J-J-BD	CC 50V 10pF 5% 0805 1.2x2.0
C1136-C1137	150F-104K-J-BD	CC 50V 0.1µF 10% 0805 1.2x2.0
DIODE		
D101	4840-0490-0	BRIDGE RECTIFIER RB152 100V 1.5A
WAFER		
J101A	2102-101S-004	WAFER 10P P2.5 ST.(COULOMB)
CONNECTORS		
J203B	2101-1581-0	FLEXIBLE CONN. 35P P1.25 SIDE ENTRY
J601B	2102-121S-004	12P ST.WAFER P=2.5 COULOMB
J604B	2102-031S-004	3 PIN ST. WAFER P=2.5 COULOMB
COILS		
L101-L104	1801-100K-M	COIL 10µH 10% BL7.0
CRYSTAL		
M101	2300-3060-0	X'TAL 12.288MHZ +/-20PPM HCMOS/TTL OSCILLATOR
TRANSISTOR		
Q101	485C-114E-5	TR DTC114ES
RESISTORS		
R101-R103	4720-103J-J	RMG 1/10W 10K 5% 0805
R104	4720-680J-J	RMG 1/10W 68R 5% 0805
R105-R109	4720-103J-J	RMG 1/10W 10K 5% 0805
R110	4707-103C-5-8	RCFA 1/2W 10K 2% RL 8 9P SIP 4609x-101-103
R111-R112	4720-103J-J	RMG 1/10W 10K 5% 0805
R113	4720-473J-J	RMG 1/10W 47K 5% 0805
R114	4720-821J-J	RMG 1/10W 820R 5% 0805
R115	4720-750J-J	RMG 1/10W 75R 5% 0805
R116	4720-473J-J	RMG 1/10W 47K 5% 0805
R117	4720-821J-J	RMG 1/10W 820R 5% 0805
R118	4720-750J-J	RMG 1/10W 75R 5% 0805
R119	4720-000J-J	RMG 1/10W 0R 5% 0805
R122	4720-151J-J	RMG 1/10W 150R 5% 0805
R123	4720-103J-J	RMG 1/10W 10K 5% 0805
R125	4720-151J-J	RMG 1/10W 150R 5% 0805
R126	4720-103J-J	RMG 1/10W 10K 5% 0805
R127	4720-104J-J	RMG 1/10W 100K 5% 0805
R129	4720-000J-J	RMG 1/10W 0R 5% 0805

<u>Reference No.</u>	<u>Part No.</u>	<u>Description</u>
R130	4720-151J-J	RMG 1/10W 150R 5% 0805
R131	4720-103J-J	RMG 1/10W 10K 5% 0805
R133	4720-151J-J	RMG 1/10W 150R 5% 0805
R134	4720-103J-J	RMG 1/10W 10K 5% 0805
R135-R136	4720-102J-J	RMG 1/10W 1K 5% 0805
R137	4720-151J-J	RMG 1/10W 150R 5% 0805
R138	4720-103J-J	RMG 1/10W 10K 5% 0805
R139	4720-102J-J	RMG 1/10W 1K 5% 0805
R140	4720-101J-J	RMG 1/10W 100R 5% 0805
R150	4720-151J-J	RMG 1/10W 150R 5% 0805
R155	4720-153J-J	RMG 1/10W 15K 5% 0805
R156-R157	4720-103J-J	RMG 1/10W 10K 5% 0805
R158	4720-151J-J	RMG 1/10W 150R 5% 0805
R159	4720-153J-J	RMG 1/10W 15K 5% 0805
R160-R161	4720-103J-J	RMG 1/10W 10K 5% 0805
R162	4720-151J-J	RMG 1/10W 150R 5% 0805
R163-R164	4720-223J-J	RMG 1/10W 22K 5% 0805
R165	4720-121J-J	RMG 1/10W 120R 5% 0805
R166	4720-201J-J	RMG 1/10W 200R 5% 0805
R167-R168	4720-103J-J	RMG 1/10W 10K 5% 0805
R169	4720-102J-J	RMG 1/10W 1K 5% 0805
R171	4720-103J-J	RMG 1/10W 10K 5% 0805
R172	4720-471J-J	RMG 1/10W 470R 5% 0805
R173	4720-103J-J	RMG 1/10W 10K 5% 0805
R181	4720-000J-J	RMG 1/10W 0R 5% 0805
R184-R185	4720-104J-J	RMG 1/10W 100K 5% 0805
R186, R189	4720-000J-J	RMG 1/10W 0R 5% 0805
R190-R192	4720-104J-J	RMG 1/10W 100K 5% 0805
R193	4720-000J-J	RMG 1/10W 0R 5% 0805
R194	4720-335J-J	RMG 1/10W 3.3M 5% 0805
ICs		
U101	3131-3980-0	IC 74HC153 QUAD 4-INPUT MUX SOP16
U102	3131-3870-0	IC 74HC157 QUAD 2-INPUT MUX SO16
U103	3131-3700-0	IC CS5331A 18BIT A/D CONVERTER CRYSTAL
U104	3130-9560-0	NJM5532 IC 'DIP8' ELE-IC029
U105	3131-3720-0	IC CS4926 DSP CRYSTAL
U106-U107	3130-8980-0	IC 74HC574 8x D-TYPE LATCHES
U108	3131-9320-0	IC AT27C020-70 256Kx8 OTP
U109	3130-9560-0	NJM5532 IC 'DIP8' ELE-IC029
U110	3130-8890-0	IC CS8414 DIR 96KHZ 24BIT
U111-U113	3131-3710-0	IC CS4340 D/A CONVERTER CRYSTAL
U114	3131-9100-0	IC 74HCU04 HEX INVERTERS (SOP)
U115	3130-6590-0	IC 74HC74 DUAL D-TYPE FLIP-FLOP
U116	3130-9560-0	NJM5532 IC 'DIP8' ELE-IC029
U117	3130-6590-0	IC 74HC74 DUAL D-TYPE FLIP-FLOP
U118, U119	3131-9050-0	IC 74HC00 QUAD 2I/P NAND GATE SOP
U120	3130-6590-0	IC 74HC74 DUAL D-TYPE FLIP-FLOP
U121	3130-5610-0	IC LM317T+ADJ REGULATOR
U123, U125	3130-2020-2	IC 7805 REG 5V
U131, U134	3130-9560-0	NJM5532 IC 'DIP8' ELE-IC029
<u>FRONT AMP BOARD</u>		
<u>ASSEMBLY</u>		
<u>PC BOARD</u>		
2401	PCB-N0910C-AMP1	PCB ASSY POWER AMP L/R/C N091XC
<u>CAPACITORS</u>		
C501-C502	157D-476M-5-IM	CE 16V 47µF 20% RL 5x7

Reference No.	Part No.	Description
C503-C504	150F-101J-5-IF	CC 50V 100pF 5% RL 5x3.5
C505-C506	157D-227M-5-KW	CE 16V 220µF 20% RL 6x12
C507-C510	157F-106M-5-IU	CE 50V 10µF 20% RL 5x11
C511-C512	150F-070D-5-GG	CC 50V 7pF 0.5pF RL 4x4
C513-C514	150F-101J-5-IF	CC 50V 100pF 5% RL 5x3.5
C515-C516	150F-181K-5-GG	CC 50V 180pF 10% RL 4x4
C517-C518	150F-223Z-5-UG	CC 50V 0.022µF +80/-20% RL 11x4
C519-C520	153F-104J-5-QUN	CM 50V 0.1µF RL (9x11) POLYESTER
C521-C522	157D-476M-5-IU	CE 16V 47µF 20% RL 5x11
C523-C524	15CH-020C-5-GG	CTC 0/60 2pF 0.25pF RL 4x4
C525-C526	157I-477M-5-x&	CE 63V 470µF 20% RL 12.5x25
C538	150F-223Z-5-UG	CC 50V 0.022µF +80/-20% RL 11x4
C541-C542	150F-101J-5-IF	CC 50V 100pF 5% RL 5x3.5
C543	15CH-020C-5-GG	CTC 0/60 2pF 0.25pF RL 4x4
C544	150F-181K-5-GG	CC 50V 180pF 10% RL 4x4
C545	157D-227M-5-KW	CE 16V 220µF 20% RL 6x12
C546	157D-476M-5-IU	CE 16V 47µF 20% RL 5x11
C547	150F-070D-5-GG	CC 50V 7pF 0.5pF RL 4x4
C548-C549	157F-106M-5-IU	CE 50V 10µF 20% RL 5x11
C550	150F-223Z-5-UG	CC 50V 0.022µF +80/-20% RL 11x4
C552	157D-476M-5-IU	CE 16V 47µF 20% RL 5x11
C553	153F-104J-5-QUN	CM 50V 0.1µF RL (9x11) POLYESTER
C561-C562	8910-0078-0	CE 63V 10000µF 20% RL 35x40
C563-C565	157F-106M-5-GM	CE 50V 10µF 20% RL 4x7
C566-C567	157D-476M-5-IU	CE 16V 47µF 20% RL 5x11
C581	157B-107M-5-KM	CE 6.3V 100µF 20% RL 6x7
C583, C592-C593	150F-223Z-5-UG	CC 50V 0.022µF +80/-20% RL 11x4
DIODES		
D501, D503	4804-0040-1	DIODE 1N4004 AL
D510	4804-1480-C	DIODE 1N4148 ATS
D511	4840-7060-0	DIODE BRIDGE RS804M
D512	4804-1480-C	DIODE 1N4148 ATS
D513-D514	4840-0850-0	ZD 1/2W 21.52-22.63V AT
D515-D520, D592-D593	4804-1480-C	DIODE 1N4148 ATS
CONNECTOR WIRES		
J501A	7706-1480-3004	CONN.ASSY 6P P2.5 L480 AWG 24
J502A	7712-1150-3004	CONN.ASSY 12P P2.5 L150 AWG24
J503A	7710-1100-3004	CONN.ASSY 10P P2.5 L100 AWG24
J504A	7706-1480-3004	CONN.ASSY 6P P2.5 L480 AWG 24
WAFERS		
J505B	2102-021S-004	2P ST.WAFER P=2.5 COULOMB
J603B	2102-061S-004	6P ST. WAFER P=2.5 COULOMB
J802B	2102-101S-004	WAFER 10P P2.5 ST. (COULOMB)
COILS		
L501-L502	1804-0540-0	SPRING COIL 1MH
RELAYS		
M501	4500-0910-0	RELAY 24VDC,125VA,3A OSA-SS-224DM3 OEG
M502	4500-0900-0	RELAY 24VDC,250VAC,10A SDT-SS-124D OEG
THERMISTOR		
M511	8910-0489-0	THERMISTOR 100C PTH9M04BD222TS2F333
WAFERS		
P501-P503	2113-1160-0	WAFER 2P ST. P=2.5 NH (JST)

<u>Reference No.</u>	<u>Part No.</u>	<u>Description</u>
TRANSISTORS		
Q501-Q506	4860-0190-5	TR 2SC1845 (F.E) RL
Q507-Q510	485A-9490-5	TR 2SA949-O HFE 70-140 TOSHIBA
Q511-Q512	485C-2229-5	TR 2SC2229-0 HFE 70-140 TOSHIBA
Q513-Q514	485A-9490-5	TR 2SA949-O HFE 70-140 TOSHIBA
Q515-Q516	485C-2229-5	TR 2SC2229-0 HFE 70-140 TOSHIBA
Q517-Q518	4860-1220-5	TR 2SC3421 (0,Y) RL TSB
Q519-Q520	485C-5171-5	TR 2SC5171 HFE 100-320
Q521-Q522	485A-1930-5	TR 2SA1930 HFE 100-320
Q523-Q524	4860-5210-5	TR 2SC5198-0 HFE 80-160 70W TOSHIBA
Q525-Q526	4860-5220-5	TR 2SA1941-0 HFE 80-160 70W TOSHIBA
Q527-Q528	4860-0190-5	TR 2SC1845 (F.E) RL
Q529-Q530	4860-1590-5	TR 2SC1740S (R) HFE180-390
Q541-Q544	4860-0190-5	TR 2SC1845 (F.E) RL
Q545	4860-1590-5	TR 2SC1740S (R) HFE180-390
Q546-Q548	485A-9490-5	TR 2SA949-O HFE 70-140 TOSHIBA
Q549-Q550	485C-2229-5	TR 2SC2229-0 HFE 70-140 TOSHIBA
Q551	485C-5171-5	TR 2SC5171 HFE 100-320
Q552	4860-1220-5	TR 2SC3421 (0,Y) RL TSB
Q553	485A-1930-5	TR 2SA1930 HFE 100-320
Q554	4860-5210-5	TR 2SC5198-0 HFE 80-160 70W TOSHIBA
Q555	4860-5220-5	TR 2SA1941-0 HFE 80-160 70W TOSHIBA
Q561-Q562	4850-992F-5	TR 2SA992 HFE 300-600
Q563	485B-772P-5	TR 2SB772P PNP POWER TR
Q564	4860-1590-5	TR 2SC1740S (R) HFE180-390
Q581-Q582	4860-0190-5	TR 2SC1845 (F.E) RL
Q583	4850-992F-5	TR 2SA992 HFE 300-600
Q591-Q592	485C-123J-5	TR DTC123JSA ROHM
RESISTORS		
R501	474B-R10K-5-02	RWR 5W 0.1Rx2 10% RL
R502	4701-221J-C	RCF 1/8W 220R 5% ATS
R503-R504	4701-273J-C	RCF 1/8W 27K 5% ATS
R505-R506	4701-471J-C	RCF 1/8W 470R 5% ATS
R507-R510	4701-180J-C	RCF 1/8W 18R 5% ATS
R511-R512	4701-562J-C	RCF 1/8W 5.6K 5% ATS
R513-R514	4701-273J-C	RCF 1/8W 27K 5% ATS
R515-R516	4701-821J-C	RCF 1/8W 820R 5% ATS
R517-R520	4701-102J-C	RCF 1/8W 1K 5% ATS
R521-R524	4717-680J-1	RMF 1/2W 68R 5% AL
R525-R526	4717-560J-2	RMF 1/2W 56R 5% AT
R527-R528	4717-680J-1	RMF 1/2W 68R 5% AL
R529-R530	4701-560J-C	RCF 1/8W 56R 5% ATS
R531-R532	4701-183J-C	RCF 1/8W 18K 5% ATS
R533-R534	4701-332J-C	RCF 1/8W 3.3K 5% ATS
R535-R536	4701-183J-C	RCF 1/8W 18K 5% ATS
R537-R538	4701-512J-C	RCF 1/8W 5.1K 5% ATS
R539-R542	4717-2R2J-2	RMF 1/2W 2.2R 5% AT
R543-R544	4705-331J-2	RCF 1/4W 330R 5% AT
R545-R546	4701-272J-C	RCF 1/8W 2.7K 5% ATS
R547-R548	474B-R22K-5-02	RWR 5W 0.22R x2 10% RL
R549-R550	4701-471J-C	RCF 1/8W 470R 5% ATS
R551-R552	4701-333J-C	RCF 1/8W 33K 5% ATS
R553-R554	4701-473J-C	RCF 1/8W 47K 5% ATS
R555-R556	4718-8R2J-2-X	RMF 1W 8.2R 5% AT
R559	4701-103J-C	RCF 1/8W 10K 5% ATS
R560	4701-223J-C	RCF 1/8W 22K 5% ATS
R561-R562	4701-271J-C	RCF 1/8W 270R 5% ATS
R563-R566	4701-104J-C	RCF 1/8W 100K 5% ATS

Reference No.	Part No.	Description
R567, R569	4717-2R2J-2	RMF 1/2W 2.2R 5% AT
R570	4701-225J-C	RCF 1/8W 2.2M 5% ATS
R571	4705-333J-2	RCF 1/4W 33K 5% AT
R572	4701-103J-2	RCF 1/8W 10K 5% AT
R575	4701-473J-2	RCF 1/8W 47K 5% AT
R577-R578	4718-R22J-2	RMF 1W 0.22R 5% AT
R580	4701-562J-C	RCF 1/8W 5.6K 5% ATS
R581	4701-273J-C	RCF 1/8W 27K 5% ATS
R582-R583	4701-102J-2	RCF 1/8W 1K 5% AT
R584	4701-104J-2	RCF 1/8W 100K 5% AT
R585-R586	4717-680J-1	RMF 1/2W 68R 5% AL
R587	4701-471J-C	RCF 1/8W 470R 5% ATS
R588	4701-180J-C	RCF 1/8W 18R 5% ATS
R589	4701-562J-C	RCF 1/8W 5.6K 5% ATS
R590	4701-180J-C	RCF 1/8W 18R 5% ATS
R591	4701-273J-C	RCF 1/8W 27K 5% ATS
R592	4701-223J-C	RCF 1/8W 22K 5% ATS
R593	4701-560J-C	RCF 1/8W 56R 5% ATS
R594	4701-271J-C	RCF 1/8W 270R 5% ATS
R595	4701-104J-C	RCF 1/8W 100K 5% ATS
R596	4717-560J-2	RMF 1/2W 56R 5% AT
R597	4717-680J-1	RMF 1/2W 68R 5% AL
R598	4701-183J-C	RCF 1/8W 18K 5% ATS
R5100	4701-512J-C	RCF 1/8W 5.1K 5% ATS
R5101	4701-183J-C	RCF 1/8W 18K 5% ATS
R5102	4701-332J-C	RCF 1/8W 3.3K 5% ATS
R5103	4705-331J-2	RCF 1/4W 330R 5% AT
R5104-R5105	4717-2R2J-2	RMF 1/2W 2.2R 5% AT
R5106	4701-272J-C	RCF 1/8W 2.7K 5% ATS
R5107	474B-R22K-5-02	RWR 5W 0.22R x2 10% RL
R5108	4701-471J-C	RCF 1/8W 470R 5% ATS
R5109	4701-333J-C	RCF 1/8W 33K 5% ATS
R5110	4718-8R2J-2-X	RMF 1W 8.2R 5% AT
R5111	4701-821J-C	RCF 1/8W 820R 5% ATS
R5112, R5117	4701-473J-C	RCF 1/8W 47K 5% ATS
R5119	4701-103J-C	RCF 1/8W 10K 5% ATS
R5120-R5121	4701-472J-C	RCF 1/8W 4.7K 5% ATS
R5122-R5123	4707-822J-2	RCF 1/2W 8.2K 5% AT
R5124-R5125	4701-122J-C	RCF 1/8W 1.2K 5% ATS
R5126	4701-561J-C	RCF 1/8W 560R 5% AT
R5130	4701-223J-C	RCF 1/8W 22K 5% ATS
R5131	4701-562J-C	RCF 1/8W 5.6K 5% ATS
R5132	4701-223J-C	RCF 1/8W 22K 5% ATS
R5133	4701-562J-C	RCF 1/8W 5.6K 5% ATS
R5134-R5135	4701-222J-C	RCF 1/8W 2.2K 5% ATS
IC		
Q565	3130-2520-3	IC 7812 12V REGULATOR
SEMI-FIXED RESISTORS		
R573-R574, R599	4756-2226-3-06	SVR 2.2K H3 7x7.6 R0615C
SURROUND AMP BOARD ASSEMBLY		
PC BOARD		
2501	PCB-N0910C-AMP2	PCB ASSY POWER AMP SL/SR N091XC
CAPACITORS		
C801-C802	157D-476M-5-IU	CE 16V 47µF 20% RL 5x11

<u>Reference No.</u>	<u>Part No.</u>	<u>Description</u>
C803-C804	150F-101J-5-IF	CC 50V 100pF 5% RL 5x3.5
C805-C806	150F-020C-5-GG	CC 50V 2pF 0.25pF RL 4x4
C807-C808	150F-471K-5-GG	CC 50V 470pF 10% RL 4x4
C809-C810	157D-227M-5-KW	CE 16V 220µF 20% RL 6x12
C811-C812	157D-476M-5-IU	CE 16V 47µF 20% RL 5x11
C813-C814	150F-181K-5-GG	CC 50V 180pF 10% RL 4x4
C815-C816	150F-070D-5-GG	CC 50V 7pF 0.5pF RL 4x4
C817-C820	157F-106M-5-GM	CE 50V 10µF 20% RL 4x7
C821-C822	150F-223Z-5-UG	CC 50V 0.022µF +80/-20% RL 11x4
C823-C824	153F-104J-5-QUN	CM 50V 0.1µF RL (9x11) POLYESTER
C829-C830	157I-477M-5-X&	CE 63V 470µF 20% RL 12.5x25
C831-C832	150F-151K-2-FC	CC 50V 150pF 10% AT 3.5x2
C833	150F-223Z-5-UG	CC 50V 0.022µF +80/-20% RL 11x4
C835-C836	150F-151K-2-FC	CC 50V 150pF 10% AT 3.5x2
DIODES		
D801-D802	4804-0040-1	DIODE 1N4004 AL
D803-D805	4804-1480-C	DIODE 1N4148 ATS
WAFERS		
J602B	2102-031S-004	3 PIN ST. WAFER P=2.5 COULOMB
JP801-JP802	2113-1160-0	WAFER 2P ST. P=2.5 NH (JST)
CONNECTOR WIRES		
J801A	7708-1150-3004	CONN.ASSY AWG24 8P P2.5 L=150
J802A	7710-1200-3004	CONN ASSY 10P P2.5 L200 AWG24
RELAY		
M801	4500-0910-0	RELAY 24VDC,125VA,3A OSA-SS-224DM3 OEG
TRANSISTORS		
Q801-Q806	4860-0190-5	TR 2SC1845 (F.E) RL
Q807-Q808	4860-1590-5	TR 2SC1740S (R) HFE180-390
Q809-Q812	485A-949O-5	TR 2SA949-O HFE 70-140 TOSHIBA
Q813-Q814	485C-5171-5	TR 2SC5171 HFE 100-320
Q815-Q816	485A-949O-5	TR 2SA949-O HFE 70-140 TOSHIBA
Q817-Q820	485C-2229-5	TR 2SC2229-0 HFE 70-140 TOSHIBA
Q821-Q822	4860-1220-5	TR 2SC3421 (0,Y) RL TSB
Q823-Q824	485A-1930-5	TR 2SA1930 HFE 100-320
Q825-Q826	4860-5210-5	TR 2SC5198-0 HFE 80-160 70W TOSHIBA
Q827-Q828	4860-5220-5	TR 2SA1941-0 HFE 80-160 70W TOSHIBA
Q829-Q830	4860-0190-5	TR 2SC1845 (F.E) RL
Q831	485C-123J-5	TR DTC123JSA ROHM
RESISTORS		
R803-R804	4701-273J-C	RCF 1/8W 27K 5% ATS
R805-R806	4701-471J-C	RCF 1/8W 470R 5% ATS
R807-R808	4701-180J-C	RCF 1/8W 18R 5% ATS
R809-R810	4701-562J-C	RCF 1/8W 5.6K 5% ATS
R811,R812	4701-180J-C	RCF 1/8W 18R 5% ATS
R813-R816	4701-102J-C	RCF 1/8W 1K 5% ATS
R817-R818	4701-104J-C	RCF 1/8W 100K 5% ATS
R819-R822	4717-680J-1	RMF 1/2W 68R 5% AL
R823-R824	4701-273J-C	RCF 1/8W 27K 5% ATS
R825-R826	4701-821J-C	RCF 1/8W 820R 5% ATS
R827-R828	4701-560J-C	RCF 1/8W 56R 5% ATS
R829-R830	4701-183J-C	RCF 1/8W 18K 5% ATS
R831-R832	4701-512J-C	RCF 1/8W 5.1K 5% ATS
R833-R834	4701-183J-C	RCF 1/8W 18K 5% ATS

Reference No.	Part No.	Description
R835-R836	4701-332J-C	RCF 1/8W 3.3K 5% ATS
R837-R838	4715-331A-2	RMF 1/4W 330R 1% AT
R839-R840	4701-471J-C	RCF 1/8W 470R 5% ATS
R841-R844	4717-2R2J-2	RMF 1/2W 2.2R 5% AT
R845-R846	4701-271J-C	RCF 1/8W 270R 5% ATS
R847-R848	4701-104J-C	RCF 1/8W 100K 5% ATS
R849-R850	4717-560J-2	RMF 1/2W 56R 5% AT
R851-R852	4717-680J-1	RMF 1/2W 68R 5% AL
R853-R854	474B-R22K-5-02	RWR 5W 0.22R x2 10% RL
R855-R856	4707-272J-2	RCF 1/2W 2.7K 5% AT
R857-R858	4718-8R2J-2-x	RMF 1W 8.2R 5% AT
R859-R860	4717-2R2J-2	RMF 1/2W 2.2R 5% AT
R861-R862	4701-333J-C	RCF 1/8W 33K 5% ATS
R863-R864	4701-473J-C	RCF 1/8W 47K 5% ATS
R865-R866	4701-223J-C	RCF 1/8W 22K 5% ATS
SEMI-FIXED RESISTORS		
R867-R868	4756-2026-3-03	SVR 2.2K H3 7x7.6 R0615C
AUDIO BOARD ASSEMBLY		
PC BOARD		
1201	PCB-N0910C-AUD	PCB ASSY AUDIO N091xC
JACKS		
1202, 1203	2113-1805-0	6P RCA JACK R/W GOLD W/SHIELD
SWITCH		
1204	5200-3171-0-01	DPDT SLIDE SW.SK-22F28-G9TS
CAPACITORS		
C301-C302	150F-103K-2-FC	CC 50V 0.01 μ F 10% AT 3.5x2
C303	157D-107M-5-IU	CE 16V 100 μ F 20% RL 5x11
C304	150F-103K-2-FC	CC 50V 0.01 μ F 10% AT 3.5x2
C305-C306	157D-476M-5-IU	CE 16V 47 μ F 20% RL 5x11
C319-C322, C325-C332	150F-101K-2-FC	CC 50V 100pF 10% AT 3.5x2
C333-C334, C337-C338	157D-335M-5-II	CE 16V 3.3 μ F 20% RL 5x5
SOCKETS		
J707B, J711B	2101-1801-0	SOCKET (PCB/PCB) 10P P2.0
TRANSISTORS		
Q302	485A-114E-5	TR DTA114ESA ROHM
Q303	485C-144E-5	TR DTC144ES ROHM
RESISTORS		
R302-R303	4701-102J-C	RCF 1/8W 1K 5% ATS
R304	4701-470J-C	RCF 1/8W 47R 5% ATS
R305	4701-103J-C	RCF 1/8W 10K 5% ATS
R331	4701-331J-C	RCF 1/8W 330R 5% ATS
R332	4701-105J-C	RCF 1/8W 1M 5% ATS
R333	4701-331J-C	RCF 1/8W 330R 5% ATS
R334	4701-105J-C	RCF 1/8W 1M 5% ATS
R335	4701-331J-C	RCF 1/8W 330R 5% ATS
R336	4701-105J-C	RCF 1/8W 1M 5% ATS
R337	4701-331J-C	RCF 1/8W 330R 5% ATS
R338	4701-105J-C	RCF 1/8W 1M 5% ATS
R339	4701-222J-C	RCF 1/8W 2.2K 5% ATS
R340	4701-105J-C	RCF 1/8W 1M 5% ATS
R341	4701-222J-C	RCF 1/8W 2.2K 5% ATS